

Statutory Instrument No. 140 of 1974

ROAD TRAFFIC ACT, 1972
(43 OF 1972)

ROAD TRAFFIC (SIGNS) REGULATIONS, 1974

(Published on the 6th November, 1974)

ARRANGEMENT OF REGULATIONS

REGULATION

PART I. *Preliminary*

1. Citation
2. Interpretation
3. Authority to display a traffic sign
4. Purpose of traffic signs
5. Classification of traffic signs
6. Types, dimensions and colours of traffic signs
7. Colour specification
8. Manner of displaying traffic signs
9. Reflectorization or illumination of traffic signs
10. Legends on traffic signs

PART II. *Class A – Signs*

11. Regulatory signs
12. Warning signs
13. Guide or informative signs

PART III. *Class B – Road Markings*

14. General provisions relating to road markings
15. Colours of road markings
16. Regulatory markings
17. Warning markings
18. Guide or informative markings

PART IV. *Class C – Road Signals*

19. Regulatory signals
20. Warning signals
 - Schedule 1
 - Schedule 2

IN EXERCISE of the powers conferred by section 127 of the Road Traffic Act, 1972, the Minister of Works and Communications hereby makes the following Regulations –

PART I. *Preliminary*

1. These Regulations may be cited as the Road Traffic (Signs) Regulations, 1974.

Inter-pretation	<p>2. In these Regulations, unless the context otherwise requires – “urban area” means the area within a township or village where a speed restriction of 50 kilometres per hour or less is in force.</p>
Authority to display a traffic sign	<p>3. A traffic sign shall only be displayed by a road or other authority empowered to do so in terms of section 77 of the Act.</p>
Purpose of traffic signs	<p>4. A traffic sign shall have one of the following purposes –</p> <ul style="list-style-type: none"> (a) regulatory, that is to say, a traffic sign which directs a road user to take or not to take specific action and failure to obey such sign shall be an offence; (b) warning, that is to say, a traffic sign calling attention to conditions on a road which are dangerous or potentially dangerous to traffic; or (c) guiding or informative, that is to say, a traffic sign indicating a destination, direction, distance, amenity, place of interest or any other similar information.
Classification of traffic signs	<p>5. Traffic signs shall be divided into the following classes and sub-classes –</p> <ul style="list-style-type: none"> (a) road signs – <ul style="list-style-type: none"> (i) regulatory signs; (ii) warning signs; and (iii) guide or informative signs; (b) road markings – <ul style="list-style-type: none"> (i) regulatory markings; (ii) warning markings; and (iii) guide or informative markings; (c) road signals – <ul style="list-style-type: none"> (i) regulatory signals; and (ii) warning signals.
Types, dimensions and colours of traffic signs	<p>6. (1) Subject to the provisions of these Regulations, the types, dimensions and colours of traffic signs shall be as illustrated under their respective letters and numbers in Schedule 1 to these Regulations, and any reference to a letter and number, in relation to a traffic sign in these Regulations, shall mean a letter and number as aforesaid.</p> <p>(2) If a traffic sign is displayed with a colour which differs in shade from the colour as specified for such sign in Schedule 1 to these Regulations or the colour specification referred to in regulation 7, the validity of such sign shall, in the absence of proof of prejudice, not be affected thereby.</p> <p>(3) Where in these Regulations a reference is made to a non-reflectorized colour, such colour shall have a semi-matt surface.</p> <p>(4) Except where both minimum and maximum dimensions are given or the context otherwise indicates, the dimensions given are minimum dimensions:</p> <p>Provided that a tolerance of 5 per cent above any such maximum and below any such minimum shall be permissible.</p> <p>(5) Where any particular traffic sign is greater than the minimum dimensions referred to in subregulation (4), the dimensions of such sign</p>

shall, as far as practicable, be proportionate to the said minimum dimensions.

(6) Where no dimensions are provided in these Regulations for a traffic sign which is a warning sign or a guide or informative sign, the dimensions of such sign and the class of road on which it is displayed shall be such as will give adequate warning or notice of the danger or object to which it relates.

7. (1) Where a traffic sign is required to be of any colour, that colour shall be in conformity with the following specifications of the South African Bureau of Standards – Colour specification

- (a) for blue, yellow, green, white or red retro-reflective material, specification CKS-191;
- (b) for yellow and white retro-reflective paints, specification CKS-192; and
- (c) for blue, yellow, green, grey, red, black or white paint, specification CKS-193.

(2) Unless provision is made to the contrary, the reverse side of a traffic sign, other than a traffic sign with an aluminium background, shall be grey.

8. (1) Subject to the provisions of these Regulations, a traffic sign shall be displayed on a road where its significance is to be applicable so as to face oncoming traffic and shall be placed in a position and at a height which is the most advantageous having regard to the design, alignment and other features of the road concerned. Manner of displaying traffic signs

(2) Subject to the provisions of these Regulations, where a standard or post is specifically erected for the display of a traffic sign –

- (a) in the case of a regulatory or warning sign, the standard or post shall be marked in alternate black and yellow horizontal bands of a minimum width of 230 mm. and a maximum width of 300 mm; and
- (b) in the case of other signs, the colour of such standard or post shall be grey or such standard or post shall be painted with aluminium paint.

9. (1) Subject to the provisions of these Regulations, a traffic sign which is intended to convey its significance also during the hours of darkness shall have a fully reflectorized symbol, legend and border, where applicable, or such sign shall be illuminated by direct lighting, either externally or internally. Reflectorization or illumination of traffic signs

(2) Where the area of a traffic sign is less than 0.28 m² the background of the sign shall also be reflectorized.

10. (1) Where in these Regulations a reference is made to the modified series E alphabet, the modified series E lower case alphabet, the series C alphabet, the modified series E figures or the series C figures for use in connexion with any legend on a traffic sign, any such series shall be as provided for in Schedule 2 to these Regulations. Legends on traffic signs

(2) The alphabet and figures to be used for road markings shall be as provided for in Schedule 2 to these Regulations.

PART II. Class A – Signs

Regulatory
signs

11. (1) The following traffic signs fall under the subclass regulatory signs –

R1 – Stop sign:

- (a) to indicate that the driver of a vehicle shall stop such vehicle with its front end in a line with such sign or, if a stop line is used in conjunction with such sign as contemplated in regulation 16, immediately behind such stop line, and that such driver shall not proceed until it is safe so to do;
- (b) in an urban area, where the width of the sidewalk is narrow and visibility of the stop sign is obstructed when displayed 2,2 m. or more above the surface of the roadway, an additional smaller stop sign may be displayed on the same support as the larger stop sign at a height of 750 mm. above such surface and the dimensions of such sign shall be as follows –

L = 380 mm;
a = 159 mm;
b = 27 mm;
c = 16 mm;
d = 63 mm; and
e = 127 mm.

R1A – Customs – stop sign, and

R1B – Police – stop sign:

Used in conjunction with sign R1, to indicate that the driver of a vehicle shall stop such vehicle with its front end in a line with such sign, or, if a stop line is used in conjunction with such sign as contemplated in regulation 16, immediately behind such stop line, and that such driver shall not proceed until permitted so to do by a customs or police officer, as the case may be.

R2 – Yield sign:

To be used at an intersection to indicate to the driver of a vehicle approaching such sign that he shall slow down and yield the right of way to all traffic on the road which is joined by the road on which he is travelling, where such traffic is so close as to constitute a danger or potential danger.

R3 – No Entry:

- (a) to indicate that the entry of all vehicular traffic is prohibited;
- (b) if the prohibition is not to apply during certain periods or to a specific class of vehicle, or to both, a guide or informative sign G44 referred to in regulation 13 shall be displayed on the same support below sign R3 indicating after the word “EXCEPT” the period during which or the class of vehicle or both to which the prohibition shall not apply.

R4 – No animal-drawn vehicle:

To indicate that no animal-drawn vehicle is permitted on the road concerned.

- R5 – No cyclist:
To indicate that no cyclist is permitted on the road concerned.
- R6A – No right turn, and
R6B – No left turn:
(a) to indicate that vehicular traffic shall not turn at the intersection immediately ahead in the direction indicated by the arrow;
(b) if the prohibition is not to apply during certain periods, or to a specific class of vehicle, or to both, a guide or informative sign G44 referred to in regulation 13 shall be displayed on the same support below sign R6A or R6B, as the case may be, indicating after the word “EXCEPT” the period during which or the class of vehicle or both to which the prohibition shall not apply.
- R7 – No U-turn:
To indicate that vehicular traffic shall not turn to face in the opposite direction.
- R8 – No overtaking:
(a) to indicate a section of the road where the driver of a vehicle shall not overtake another vehicle travelling in the same direction;
(b) the sign indicates a prohibition over a distance of 500 m;
(c) if the prohibition is to apply over a distance of more than 500 m, the sign shall be repeated at intervals of 500 m. and the first no overtaking sign shall indicate in kilometres such distance, separately on information sign G44 and every subsequent no overtaking sign shall likewise indicate the distance in kilometres, as reduced.
- R9 – No parking:
To indicate, subject to the provisions of subregulation (2), that the parking of vehicles is at all times prohibited.
- R10 – No stopping:
To indicate, subject to the provisions of subregulation (2), that the stopping of vehicles is at all times prohibited.
- R11 – Limited hours no parking:
To indicate, subject to the provisions of subregulation (2), that the parking of vehicles is prohibited from Mondays to Saturdays during certain hours.
- R12 – Limited hours no stopping:
To indicate, subject to the provisions of subregulation (2), that the stopping of vehicles is prohibited from Mondays to Saturdays during certain hours.
- R13A and R13B – Three periods no parking or stopping:
To indicate, subject to the provisions of subregulation (2), that after the insertion of the letter P or S, as the case may be, the parking or stopping of vehicles is prohibited during any period specified on the sign.

- R14 – Speed limit:
To indicate, by means of a number, the maximum speed in kilometres per hour at which vehicular traffic may travel.
- R14A – Permissible maximum weight:
To indicate that any vehicle with its load exceeding the weight shown in metric tons on the sign is prohibited from using the road.
- R14B – Axle weight-load limit:
To indicate that a vehicle with any axle weight-load exceeding the limit shown in metric tons on the sign is prohibited from using the road.
- R15 – Road closed:
To indicate that a road is temporarily closed to traffic for road construction or other purposes.
- R16A -- and R16B – Stop/Go:
(a) to indicate that the driver of a vehicle shall stop such vehicle with its front end in a line with the stop sign and that such driver shall not proceed until permitted so to do by the display of the “Go” sign;
(b) these signs shall be displayed back to back, so that the legend “STOP” is displayed on the one side and the legend “GO” on the other side;
(c) the signs may be mounted on a pedestal or staff to permit easy rotation.
- R17 – Keep left:
To indicate that the driver of a vehicle shall keep to the left-hand side of an obstacle in the road, e.g. a traffic island.
- R18A – Proceed left only,
R18B – Proceed right only, and
R18C – Proceed straight on only:
To indicate that the driver of a vehicle shall proceed only in the direction indicated by the arrow.
- R19A – Turn right, and
R19B – Turn left:
To indicate that the driver of a vehicle on approaching an intersection shall turn only to the right or to the left, as the case may be, where the straight through and left turn, or the straight through and right turn movements respectively are not permitted.
- R20 – Minimum speed:
To indicate by means of a number, the minimum speed in kilometres per hour at which a driver of a vehicle on a road shall drive, except for any cause beyond his control.
- R21 – Cyclists only:
To indicate that a portion of a road has been reserved for cyclists only and that cyclists shall not use any other portion of that road.

R22 -- Limited parking:

To indicate, subject to the provisions of subregulation (2), that the parking of vehicles shall only be allowed for the period indicated on the sign, either throughout the day or during the hours indicated thereon.

(2) Any other regulatory sign may be displayed which –

- (i) if it is to convey a prohibition, shall be a disc with a blue background surrounded by a red circle of the size applicable to sign R4; or
- (ii) if it is to convey any other regulatory direction, shall be a disc with a blue background with a white border of the size applicable to sign R17,

with the appropriate prohibition or regulatory direction indicated within the sign in white reflectorized letters of the series C alphabet or in white reflectorized figures of the series C figures, 51 mm. high or on a guide or informative sign G44 referred to in regulation 13.

(3) A regulatory sign –

- (a) relating to the parking of a vehicle shall be displayed at each end and on that side of the section of a road where its significance is to be applicable:

Provided that –

- (i) no intersection shall be included in any such section of a road;
- (ii) any other traffic sign may be displayed within any such section in which event such traffic sign shall prevail over any sign relating to the parking of a vehicle;
- (iii) in respect of any section of a road which lies between the nearest intersection roads and which does not exceed 75 m. in length, parking may be prohibited or restricted in such section by displaying only one appropriate sign;
- (iv) where its significance is to apply to any portion of a road other than the side of such road, such sign may be displayed on that portion of such road to which its significance is to apply or on any traffic island or other raised area surrounded by the roadway of such road adjacent to such portion and in such case its significance shall apply to any parking bay demarcated at a distance of not more than 500 mm. from such sign and, if that bay is one of several demarcated parking bays adjoining one another, to all such adjoining parking bays lying within a distance of 75 m. from such sign and for the purposes of this subparagraph parking bays demarcated within 2,5 m. of each other shall be deemed to be adjoining parking bays;

(b) prohibiting or restricting the stopping of a vehicle shall be displayed at each end and on that side of the section of a road where its significance is to be applicable:

Provided that –

- (i) no intersection shall be included in any such section of a road; and
- (ii) in respect of any section of a road which lies between the nearest intersecting roads and which does not exceed 75 m. in length, stopping may be prohibited or restricted in such section by displaying only one appropriate sign; and

(c) relating to the parking or stopping of a vehicle shall, unless it is displayed with the face parallel to the lateral line of the road, display a similar sign on the reverse side.

Warning signs **12.** (1) Where a warning sign is displayed, it shall be in advance of the danger or potential danger to which it refers and shall signify that a reduction of speed may be required for safe driving.

(2) The following signs fall under the subclass warning signs –

W1 – Crossroads:

To warn traffic that a crossroad is ahead.

W2 – T-Junction:

To warn traffic that a T-junction is ahead where traffic is required to make a sharp turn either to the left or to the right.

W3A and W3B – Side-road junction from the left or the right:

To warn traffic that joining or leaving traffic or a restricted sight distance may make the junction ahead dangerous or potentially dangerous.

W4A and W4B – Staggered junction:

To warn traffic that joining or leaving traffic or a restricted sight distance may make closely situated junctions ahead dangerous or potentially dangerous.

W5A and W5B – Sharp junction from the left or the right:

To warn traffic that joining or leaving traffic or a restricted sight distance may make the sharp junction ahead dangerous or potentially dangerous.

W6A and W6B – Skew junction:

To warn traffic that joining or leaving traffic or a restricted sight distance may make the skew junction ahead dangerous or potentially dangerous.

W7 – Y-Junction:

To warn traffic that a Y-junction is ahead on the road that forms the stem of the Y.

- W8 – Traffic circle:
To warn approaching traffic that the manoeuvre at the junction ahead is clockwise round a traffic island.
- W9A and W9B – Gentle curve to the right or to the left:
To warn traffic of a gentle curve ahead to the right or to the left.
- W10A and W10B – Sharp curve to the right or to the left:
To warn traffic of a sharp curve ahead to the right or to the left.
- W11A and W11B – Hairpin bend to the right or to the left:
To warn traffic of a sharp bend ahead with almost complete direction change, to the right or to the left.
- W12A and W12B – Reverse curves:
(a) to warn traffic of a series of curves on the road ahead;
(b) the symbol on the sign shall indicate the general alignment of the road ahead.
- W13A1 and W13A2 – End of dual roadways:
To warn traffic that a one-way roadway is ending and that a roadway with traffic travelling in both directions is about to be entered.
- W13B1 and W13B2 – Beginning of dual roadways:
To warn traffic that a roadway with traffic travelling in both directions is ending and that a one-way roadway is about to be entered.
- W14 – Two-way traffic:
To warn traffic that the roadway ahead carries traffic in both directions.
- W15 – Road narrows from both sides:
To warn traffic that the roadway ahead narrows from both sides.
- W16A and W16B – Road narrows from one side only:
To warn traffic that the roadway ahead narrows from the right or left side only.
- W17A – Pedestrians:
To warn traffic of the possible presence of pedestrians ahead.
- W17B – Pedestrian crossing:
To warn traffic of an uncontrolled pedestrian crossing ahead.
- W18 – Children:
To warn traffic of the possible presence of children near schools, playgrounds or other places.
- W19 – Cyclists:
To warn traffic of the possible presence of cyclists.
- W20A – Cattle,
W20B – Horses, and
W20C – Sheep:

- (a) to warn traffic, where displayed to the left of a road, of the possible presence of cattle, horses or sheep, as the case may be;
- (b) where the signs are temporarily displayed on a road, such signs shall be a warning that cattle, horses or sheep are crossing the road ahead;
- (c) portable signs may be displayed in the centre of the road on opposite sides of the place where the cattle, horses or sheep are about to cross or are crossing, each at a distance of not less than 90 m. from such place;
- (d) any such portable sign may be displayed at any height and shall be displayed so as to face away from the place of crossing and in the direction of traffic approaching the crossing;
- (e) any such portable sign shall only be displayed for the duration of a particular crossing and shall be removed when the crossing of the cattle, horses or sheep has been completed;
- (f) the reverse side of any such portable sign shall be red and white non-reflectorized diagonal stripes 150 mm. wide.

W20D – Wild animals:

To warn traffic of the possible presence of wild animals.

W21 – Uneven road:

To warn traffic that there is a dip or drain in the road or an uneven road ahead.

W22A and W22B – Falling rocks:

To warn traffic of the possibility of falling rocks or stones on the left or the right of the road ahead.

W23 – Slippery road:

To warn traffic of abnormal slippery conditions of the road ahead.

W24 – Drift:

To warn traffic of a drift ahead which may contain water, rock outcrops or loose material.

W25 – Jetty edge or river bank:

To warn traffic that the road ahead leads to a jetty edge or a river bank.

W26 – Height restricted:

- (a) to warn traffic that clearance of an overhead structure over the full width of the road ahead is that shown on the sign;
- (b) the sign shall be displayed in advance of the structure as well as on the structure itself;
- (c) the sign on the structure shall be flanked on the left side and on the right side by a danger plate G42, 900 mm. wide and 300 mm. high with diagonals 150 mm. wide, of red and white reflectorized material.

W27 – Gate:

To warn traffic that a road ahead is closed by a gate or to warn traffic of the presence of a level crossing with gates.

W28A, W28B and W28C – Cattle grid:

To warn traffic that a cattle grid is ahead to the left or to the right or in the middle of the road.

W29 – One vehicle width structure:

To warn traffic that a structure on the road ahead restricts the width of the road to less than 5 m. and that traffic shall stop at the entrance thereto if a vehicle approaching from the opposite direction is already on the structure or so close thereto as to constitute a danger.

W30 – Tunnel:

To warn traffic of the presence of a tunnel on the road ahead in which the use of headlights may be required.

W31 – Unguarded level crossing:

- (a) to warn traffic of a level crossing ahead which is not controlled by booms, signals or flagmen;
- (b) for additional emphasis the sign may also be displayed on the right-hand side of the road.

W32A1 and W32A2 – Steep descent:

To warn traffic of a steep descent ahead either to the right or to the left, as the case may be.

W32B1 and W32B2 – Steep ascent:

To warn traffic of a steep ascent ahead either to the left or to the right, as the case may be.

W33 – Cross winds:

To warn traffic of the possibility of severe cross winds ahead which may deflect a vehicle from its course.

W34 – Traffic signals ahead:

To warn traffic of the presence of a traffic control signal ahead.

W35 – School patrol ahead:

- (a) to warn traffic of a school patrol ahead;
- (b) the sign shall be a portable sign and shall be displayed only for the period during which the school patrol is in operation;
- (c) the sign may be displayed in the centre of a two-way road or on the median island of a dual road.

W36 – Trucks crossing:

To warn traffic that heavy trucks regularly cross the road ahead or that road construction or maintenance work ahead may create a danger.

W37 – Grader working:

To warn traffic that a grader is working on the road ahead and that road construction or maintenance work ahead may create a danger.

W38 – Loose stones:

To warn traffic of the presence of loose stones or gravel on the road ahead.

W39 – STOP/GO control ahead:

To warn traffic that traffic ahead is controlled by a portable STOP/GO sign R16A/R16B.

W40 – Road workmen:

To warn traffic that road construction or maintenance work with manual labour is in progress ahead.

W41 – Hazard ahead:

To warn traffic of a hazard ahead not otherwise provided for.

W42A, W42B and W42C – Level crossing warning cross:

To warn traffic that a level crossing with one or more tracks is ahead.

(3) Warning signs shall also conform to the following requirements –

- (a)** the border of signs W1 to W34 inclusive, W38 and W41 shall be red reflectorized while the symbol or legend, or the symbol and legend, as the case may be, of such signs shall be white reflectorized on a blue reflectorized background:

Provided that the symbols on sign W34 shall be red, amber and green reflectorized on a white reflectorized background;

- (b)** the border of signs W42A, W42B and W42C shall be red reflectorized while the inner crosses shall be white non-reflectorized.

- (4)** Any other warning sign may be displayed which shall be of the shape, size and colour of sign W1:

Provided that in lieu of the white symbol on sign W1 the danger may be indicated within the sign in white reflectorized letters of the series C alphabet or in white reflectorized figures of the series C figure 51 mm. high.

Guide or
informative
signs

13. (1) The following signs fall under the subclass guide or informative signs –

G1A – One-way road, left, and

G1B – One-way road, right:

To indicate a one-way road ahead either to the left or to the right.

G2 – One-way road, straight on:

To indicate a one-way road straight on.

G3 – Parking area ahead:

To indicate the distance ahead to a parking area to the right or left of the road as indicated by the arrow.

- G4 – Parking area direction:
To indicate the direction and distance to a parking area.
- G5 – Stopping place ahead:
To indicate the distance ahead of a stopping place to the left or right of the road as indicated by the arrow.
- G6 – Minor airfield direction:
To indicate the direction and distance to a minor airfield.
- G7 – Hospital or first-aid post:
To indicate the distance to, or to a turn-off to, a hospital or official first-aid post.
- G8 – Hospital or first-aid post direction:
To indicate the direction and distance to a hospital or first-aid post.
- G9 – Hotel or motel:
To indicate the distance to, or to a turn-off to, an hotel or motel.
- G10 – Hotel or motel direction:
To indicate the direction and distance to an hotel or motel.
- G11 – Caravan site:
To indicate the distance to, or to a turn-off to, a caravan site.
- G12 – Caravan site direction:
To indicate the direction and distance to a caravan site.
- G13 – Camping site:
To indicate the distance to, or to a turn-off to, a camping site.
- G14 – Camping site direction:
To indicate the direction and distance to a camping site.
- G15 – Caravan and camping site:
To indicate the distance to, or to a turn-off to, a caravan and camping site.
- G16 – Caravan and camping site direction:
To indicate the direction and distance to a caravan and camping site.
- G17 – Restaurant:
To indicate the distance to, or to a turn-off to, a restaurant.
- G18 – Restaurant direction:
To indicate the direction and distance to a restaurant.
- G19 – Filling station:
To indicate the distance to, or to a turn-off to, a filling station.
- G20 – Filling station direction:
To indicate the direction and distance to a filling station.
- G21 – Filling and service station:
To indicate the distance to, or to a turn-off to, a filling and service station.

- G22 – Filling and service station direction :
To indicate the direction and distance to a filling and service station.
- G22A – Telephone direction :
To indicate the direction and distance to a telephone.
- G22B – Police station direction :
To indicate the direction and distance to a police station.
- G23 – Water ahead :
To indicate the distance ahead where water is available.
- G24 – Major route marker :
To indicate the number of a major route.
- G25 – Minor road route marker :
To indicate the number of a minor road route.
- G26 – Stop ahead :
To indicate the distance ahead of a stop sign.
- G27 – De-restriction :
(a) to indicate where a traffic sign shall no longer apply ;
(b) the symbol or legend on the de-restriction sign shall correspond to the symbol or legend on the traffic sign which it de-restricts ;
(c) the diagonal cross on the de-restriction sign shall only be interrupted in the case of the de-restriction of a maximum or minimum speed limit ;
(d) a de-restriction sign shall not be required where –
(i) one speed limit is substituted for another speed limit ;
(ii) one minimum speed is substituted for another minimum speed ;
(iii) a minimum speed is substituted for a speed limit ; or
(iv) a speed limit is substituted for a minimum speed ;
(e) any other de-restriction sign may be displayed which complies with the requirements of paragraphs (b) and (c).
- G28 – Cul-de-sac :
To indicate that the road ahead runs to a dead end.
- G29 – Bus stop :
(a) to indicate a bus stop ;
(b) the name of the bus service may be indicated at the top of the sign in letters 25 mm. high.
- G30 – Town name :
To indicate in advance that the built-up area of a town is being approached where a reduced speed limit will apply.

- G31 – River name:
To indicate in advance of a bridge over a river, the name of such river.
- G32A – Road works ahead:
To indicate that major road work operations are taking place ahead.
- G32B – Thank you:
This sign may be displayed on the reverse side of sign G32A.
- G33 – End of detour:
To indicate the distance ahead where a detour ends.
- G34 – Detour ahead:
To indicate the distance ahead where a detour commences.
- G35 – Map type four-legged intersection:
To indicate in advance of a major intersection a plan view of the alignment of such intersection with the direction of the appropriate destination names correctly shown.
- G36 and G37 – Map type four-legged staggered intersection and map type traffic circle junction:
The provisions relating to sign G35 shall apply *mutatis mutandis* to signs G36 and G37.
- G38A – Direction:
To indicate a route direction on a major road.
- G38B – Minor route direction:
To indicate a route direction on a major road.
- G39 – Stack type direction:
(a) to indicate in advance of an intersection on a major road, where traffic may enter or leave such intersection. Such sign shall contain not more than four destination names;
(b) the sign shall be repeated at the intersection.
- G40 – Confirmation:
(a) to indicate beyond the intersection of two major routes the distance to the destination immediately ahead and the route-end destination;
(b) in special cases where the route is leading to two major towns, or to an airport, a third destination with distance may be displayed;
(c) the sign shall be displayed on the same support below the route marker sign G24 or G25.
- G41 – Airport direction:
(a) this sign may be displayed at an intersection of a road leading to a major airport as provided under sign G38;
(b) the sign may be incorporated in a stack-type direction sign G39.

G42A and G42B – Danger plates:

- (a) to indicate a dangerous obstruction on or near the shoulder of the road;
- (b) the diagonals shall slope down towards the side on which traffic shall pass the obstruction.

G43 – Junction chevron:

To indicate sharp left and right direction changes at a junction ahead.

G44A – Recommended speed information plate:

This sign may be displayed on the same support below any other warning sign to indicate a safe speed at which the danger ahead can be negotiated.

G44B – Distance information plate:

To indicate the distance over which any other traffic sign is applicable and the sign shall be displayed with the upper edge 150 mm. below the main road sign.

(2) **Guide or informative signs shall conform to the following requirements –**

- (a) the border and symbol or legend or the border, symbol and legend, as the case may be, of signs G1A to G6 inclusive, G9 to G23 inclusive, G25, G26, G29 to G31 inclusive, G32B to G41 inclusive, G44A and G44B shall be white reflectorized on a green reflectorized background;
- (b) the border of signs G7 and G8 shall be white reflectorized while the legend shall be white reflectorized on a green reflectorized background, and the cross shall be red reflectorized on a white reflectorized background;
- (c) the border and legend of sign G24 shall be white reflectorized on a green reflectorized background;
- (d) the border and legend or symbol, as the case may be, of sign G27 shall be white reflectorized on a blue reflectorized background;
- (e) the border of sign G28 shall be white reflectorized while the horizontal part of the symbol shall be red reflectorized and the vertical part of the symbol shall be white reflectorized on a green reflectorized background;
- (f) the legend of sign G29 shall be white non-reflectorized on a black non-reflectorized background;
- (g) the border of sign G32A shall be red reflectorized and white reflectorized squares while the legend and the line shall be white reflectorized on a green reflectorized background;
- (h) signs G49A and G49B shall consist of alternating white and red reflectorized diagonal stripes; and
- (i) sign G43 shall consist of alternating yellow reflectorized and black diagonal stripes.

PART III. Class B – Road Markings

14. (1) Road markings shall be lines, patterns, words, colours or other devices, except road signs, embedded in or applied or attached to the road or kerbing or to objects within or adjacent to the road for the purpose of regulating, warning or guiding traffic.

General provisions relating to road markings

(2) Road markings may also be used to supplement the significance of a road sign.

(3) A broken line in relation to a road marking shall, in an urban area, be a broken line with segments of 2,7 m. in length and with gaps of 4,5 m. in length separating such segments and, in any other area, with segments of 4,5 m. and with gaps of 7,5 m. and the ratio between segments to gaps shall in all cases be 3 to 5.

(4) All road markings shall, except where otherwise provided, be 100 mm. in width.

15. (1) Subject to the provisions of these Regulations, road markings shall be either white or yellow.

Colours of road markings

(2) Yellow shall be used only for marking the edge of a road where parking is prohibited, for regulatory arrows and for demarcating a traffic island.

(3) All other road markings shall be white:

Provided that black may be used in lieu of white to form a contrast with a light coloured road.

16. (1) The following road markings fall under the subclass regulatory markings –

Regulatory markings

RM1 – Barrier line:

(a) a barrier line shall be a continuous white line 100 mm. in width and 15 m. in length which may replace a centre-line or lane line or may be placed on the side of any such line and shall be laid down to regulate traffic where a dangerous condition, such as a short horizontal or vertical sight distance, exists;

(b) no person shall drive any vehicle with any wheel thereof upon that part of the road which is to the right of any barrier line;

(c) where a barrier line is used in combination with a centre-line or lane line, the provisions of paragraph (b) shall only apply to traffic travelling on the same side of the centre-line or lane line as that on which the barrier line is laid down;

(d) for the purpose of paragraph (a) or (c).

(i) a centre-line shall be a broken white line 100 mm. in width used to designate the centre or approximate centre of a road; and

(ii) a lane line shall be a broken white line 100 mm. in width and shall be used for the purpose of demarcating a traffic lane.

RM2 – Channelizing line:

A channelizing line shall be a continuous white line 200 mm. in width, 15 m. in length and shall be used for the purpose of regulating the flow of traffic at intersections or where changes in the width of the road occur so that conflicting movement of traffic may be properly regulated and it shall have the same force and effect as a barrier line.

RM3 – Stop line:

A stop line shall –

- (a) be a continuous white line 300 mm. in width in an urban area and 500 mm. in any other area;
- (b) subject to the provisions of paragraph (e), extend across the full width of all approach lanes;
- (c) be sited between the centre and the edge of the road;
- (d) only be laid down at a place where traffic is required to stop by a traffic sign or by a police officer;
- (e) where filtration against an authorized control is allowed, not extend the full width of the traffic lane nearest to the left-hand edge of the road; and
- (f) have the significance assigned thereto under road sign R1.

RM4 – Pedestrian crossing lines:

Pedestrian crossing lines shall –

- (a) be two continuous white lines 100 mm. wide;
- (b) be laid down to form a lane 2 m. wide across the entire road;
- (c) only be laid down at or immediately adjoining an intersection or any other place where pedestrians cross while vehicular traffic is controlled by a traffic sign or by a police officer.

RM5 – Block pedestrian crossing:

A block pedestrian crossing shall –

- (a) consist of a distinctly marked pattern as illustrated; and
- (b) be laid down to form a lane 2 m. wide across the entire road.

RM6 – Parking bays:

- (a) where parallel parking is to be permitted, such parking shall be indicated in accordance with the layout referred to under regulatory marking RM6;
- (b) where angle parking is to be permitted, such parking shall be indicated by two parallel lines at the required angle and appropriately spaced;
- (c) any regulatory marking relating to parking shall only be laid down to supplement the significance of a traffic sign relating to parking or in conjunction with a parking meter;
- (d) if a parking line is laid down parallel to a kerb line at a distance of not more than 2.5 m. from such kerb line, the

area between such kerb line and such parking line shall be deemed to have been sufficiently demarcated;

- (e) the significance of parking lines shall be –
 - (i) if they have been laid down to constitute a parking bay, that a vehicle shall be parked wholly within such bay;
 - (ii) if they have been laid down for angle parking at the side of a road with a raised kerb, that a vehicle shall be parked wholly between such lines at the angle indicated by such lines and with the left front wheel within 150 mm. of such kerb; or
 - (iii) if they have been laid down for angle parking at the side of a road not having a raised kerb, that the vehicle shall be parked wholly between such lines at the angle indicated by such lines and as far as possible on the verge adjacent to such road without encroaching on any sidewalk;
- (f) where parking is totally prohibited such prohibition shall be indicated by a continuous yellow line which demarcates the area of prohibition and shall only apply to a road which is subject to a speed limit not exceeding 50 km. per hour.

RM7 – Exclusive parking bays:

- (a) where a particular area is required for the exclusive parking of a certain type of vehicle, the area shall be demarcated by a continuous yellow line and the type of vehicle which may park in any such demarcated area shall be as indicated under RM7:

Provided that in the case of a loading zone, such zone may only be occupied by a goods vehicle and only for a period of time not greater than is reasonably necessary for the loading or unloading of such goods vehicle;

- (b) the regulatory marking indicating for which type of vehicle the particular area is required, shall be painted centrally outside such area and adjacent thereto and where the demarcated area is longer than 30 m. at least two such markings shall be so displayed;
- (c) the provisions of paragraph (e) under RM6 shall apply *mutatis mutandis*.

RM8 – Directional arrows:

- (a) for the purpose of controlling the movement of traffic approaching an intersection, yellow directional arrows may be marked within specific lanes on the road as illustrated under RM8;
- (b) in conjunction with these arrows, the word “ONLY” may be displayed on the road concerned;
- (c) where such directional arrows have been marked on the road, no person shall drive any vehicle in the lane concerned in a direction other than that indicated by the arrow.

Warning markings –

17. The following road markings fall under the subclass warning markings –

WM1 – Level crossing:

To warn traffic of an unguarded level crossing ahead; the level crossing marking illustrated under WM1 may be marked on the road.

Guide or informative markings –

18. The following road markings fall under the subclass guide or informative markings –

Centre-line:

To indicate the centre or approximate centre of a road, a centre-line as illustrated under RM1 (barrier line) shall be used.

Lane line:

To demarcate a traffic lane, a lane line as illustrated under RM1 (barrier line) shall be used.

Painted island:

To indicate an area on the road, where vehicular traffic may not encroach and where traffic should be channelized, a painted island as illustrated under RM1 may be displayed.

GM2 – Yield sign ahead:

To indicate the presence of a yield sign R2 ahead.

GM3 – Barrier line ahead:

To indicate the presence of a barrier line RM1 ahead.

GM4 – Information arrow:

To indicate to traffic the direction of travel on a particular lane or road.

PART IV. Class C – Road Signals

Regulatory signals –

19. (1) The following road signals fall under the subclass regulatory signals –

RS1 – Robot:

(a) in the provisions relating to a robot, unless the context otherwise indicates –

“lens” means that part of a signal face which directs the light emitted by a lamp and reflected by a reflector;

“light indication” means the light emitted by a lens;

“signal face” means that part of a signal head intended for the control of traffic approaching from one direction and consists of several optical units each with a lens, reflector, a lamp and a lamp socket; and

“signal head” means an assembly of one or more signal faces;

(b) the following requirements shall be observed in respect of the displaying of a robot as illustrated in RS1 –

(i) at an intersection, there shall be at least two signal heads for vehicular traffic, one on either side of the road,

with both on the far side of the intersection for the control of traffic entering the intersection from any one direction and at any place which is not an intersection one signal head shall be sufficient:

Provided that –

- (aa) in the case of an intersection which is a T-junction, a robot may be situated centrally in such intersection and, in such event, only one signal head shall be so required;
- (bb) in the case of a divided road, the right-hand signal head shall be situated on the median island;
- (cc) where signal faces on the far side of the intersection may not be readily seen by approaching traffic, additional signal heads may be placed on the near side of the intersection or additional signal heads may be situated above the road or for extra emphasis twin light indications may be used;
- (ii) each signal face of a robot for vehicular traffic shall have at least three lenses;
- (iii) where a signal face of a robot has three lenses the top-most lens shall be red, the central lens amber and the lowest lens green, arranged vertically and not more than 150 mm. apart;
- (iv) a green arrow lens or lenses may be used in conjunction with a robot, in which event the green arrow lens or lenses shall be either immediately below or immediately to the left or right of the green lens of the robot or a green arrow lens or lenses may be used in lieu of the green lens of the robot;
- (v) the diameter of a lens shall be 200 mm;
- (vi) each lens of a robot shall be independently lit by a clear lamp of not less than 60 watts capacity;
- (vii) the design of a robot shall be such as to prevent, as far as possible, any signal face from being seen from a direction to which its light indications do not apply;
- (viii) the light sequence shall be: red, green, amber, and the time cycle shall be such as may be required for the movement of traffic;
- (ix) during certain periods the red and green lights of a robot may not be justified and in such event a flashing amber light may be shown alone; and
- (x) where it is considered desirable on account of advertising signs or any other reason, a screen may be erected behind the signal face of a robot so as to throw it into relief for oncoming traffic and the colour of the screen shall be white but may be varied having regard to the background;

- (c) only the following different light indications may be used either singly or in combination --
- (i) a steady circular red indication;
 - (ii) a flashing circular red indication;
 - (iii) a steady circular green indication;
 - (iv) a steady green arrow indication;
 - (v) a flashing green arrow indication;
 - (vi) a steady circular amber indication; or
 - (vii) a flashing circular amber indication;
- (d) the significance of a steady circular red indication shall be that --
- (i) vehicular traffic facing such indication shall stop on the near side of the stop line and shall remain stationary until the green alone is shown:

Provided if at an intersection any green arrow lens is illuminated at the same time, the movement permitted by the arrow may be made cautiously subject to the right of priority of pedestrians and vehicular traffic lawfully within such intersection; and
 - (ii) any pedestrian facing such indication shall not enter the road unless a pedestrian control signal permits otherwise;
- (e) the significance of a flashing circular red indication shall be that vehicular traffic facing such indication shall stop on the near side of the stop line and the driver may thereafter proceed against such red indication if he has satisfied himself that it is safe so to do;
- (f) the significance of a steady circular green indication shall be that --
- (i) vehicular traffic facing such indication may proceed straight through or at an intersection may turn to the left or to the right, subject to any restricting traffic sign, but shall yield the right of way to other vehicular traffic and to pedestrians lawfully within the intersection or a pedestrian crossing at the time such indication is displayed; and
 - (ii) pedestrians facing such indication may proceed across the road within any pedestrian crossing;
- (g) the significance of a steady green arrow indication shall be that --
- (i) vehicular traffic in the appropriate traffic lanes and facing such indication may proceed or at an intersection turn in the direction indicated by such arrow subject to the right of priority of pedestrians and vehicular traffic lawfully within such intersection or a pedestrian crossing at the time such indication is displayed; and

- (ii) pedestrians facing such indication may proceed across the road within the appropriate pedestrian crossing;
- (h) the significance of a flashing green arrow indication, which shall only be displayed at an intersection in conjunction with a steady red indication for vehicular traffic travelling in the opposite direction, shall be that vehicular traffic in the appropriate traffic lanes and facing such green arrow indication, may proceed in the direction indicated by the flashing arrow, subject to the right of priority of pedestrians and vehicular traffic lawfully within the intersection or a pedestrian crossing at the time such indication is displayed;
- (i) the significance of a steady circular amber indication shall be that –
 - (i) vehicular traffic facing such indication shall stop on the near side of the stop line and shall remain stationary until green alone is shown:

Provided that if the vehicle is so close to the stop line when amber appears after green that the stop cannot be made safely the driver may proceed cautiously against such amber indication; and
 - (ii) any pedestrian facing such amber indication shall not enter the road unless a pedestrian control signal permits otherwise;
- (j) the significance of a flashing circular amber indication to vehicular traffic approaching such indication shall be the same as that laid down for sign R2 (yield sign);
- (k) in conjunction with a robot a pedestrian signal consisting of a red silhouette of a man standing and a green silhouette of a man walking may be used and in such circumstances the robot indications shall not apply to pedestrians. The red silhouette shall signify that pedestrians shall not enter the intersection or block pedestrian crossing and that pedestrians who have already entered shall cross. The red silhouette may be flashed during the period allowed for pedestrians who have already entered to cross. The green silhouette shall signify that pedestrians may enter and cross the intersection or block pedestrian crossing;
- (l) in the case of a robot, the standard or post shall be painted or marked in alternate black and white horizontal bands of a minimum width of 230 mm. and a maximum width of 300 mm; except for the lowest band and any interruption of the bands by signal heads, the width of the bands on a standard or post shall be consistent.

(2) Cones placed on a road may be used by a road authority or a police officer to divert traffic from any hazard or other danger.

20. The following traffic signals fall under the subclass warning signals – Warning signals

- (a) red flashing signal:

- (i) the function and significance of a red flashing signal which is not part of a road sign shall be to draw the attention to places where the driver of a vehicle is required to stop and not proceed before it is safe so to do, and such signal shall have the same force and effect as stop sign R1;
 - (ii) a red flashing signal at a level crossing, when such signal is in operation, shall have the function, legal effect and significance that the driver of a vehicle shall stop and shall wait until the light shall cease to flash;
- (b) amber flashing signal:
- To warn traffic of the presence of a particular danger where more than ordinary caution is required, an amber flashing light may be displayed.

SCHEDULE 1
CLASS A - ROAD SIGNS.
REGULATORY SIGNS.

R1



STOP SIGN

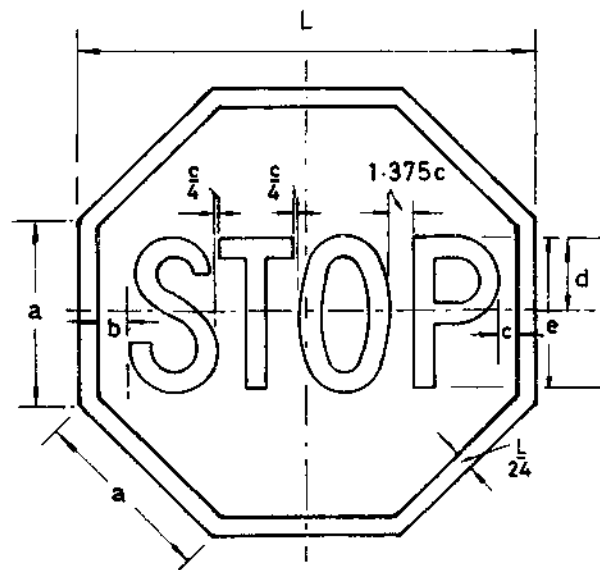

Border and legend: White reflectorized.
 Background: Red reflectorized.
 Letters: Series C alphabet.

Dimensions mm.					
L	a	b	c	d	e
610	254	44	25	102	203

R1A

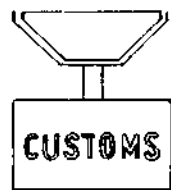

CUSTOMS STOP SIGN

R1B



POLICE STOP SIGN

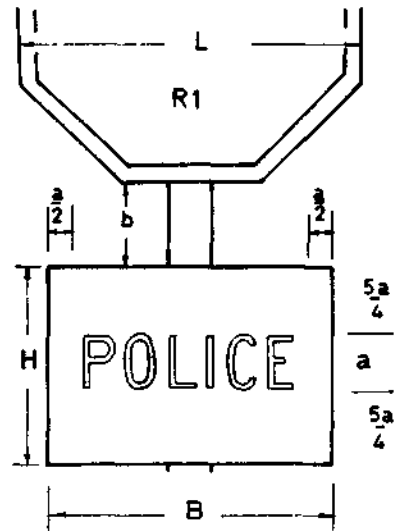
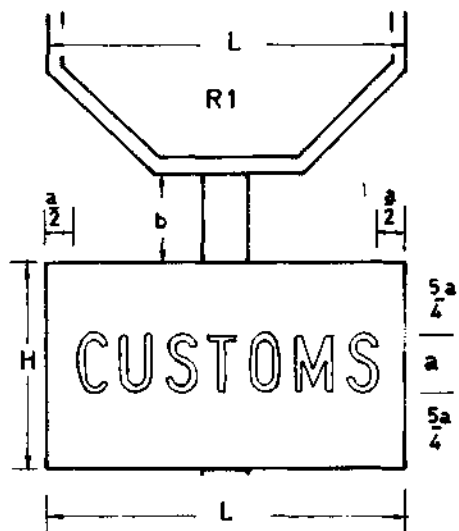

Letters: Series C alphabet, White reflectorized.
Background: Green reflectorized.

Dimensions mm.				
L	B	H	a	b
610	508	356	102	152

R 2

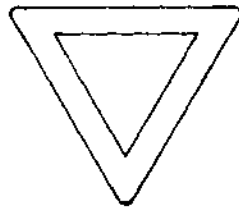

YIELD SIGN

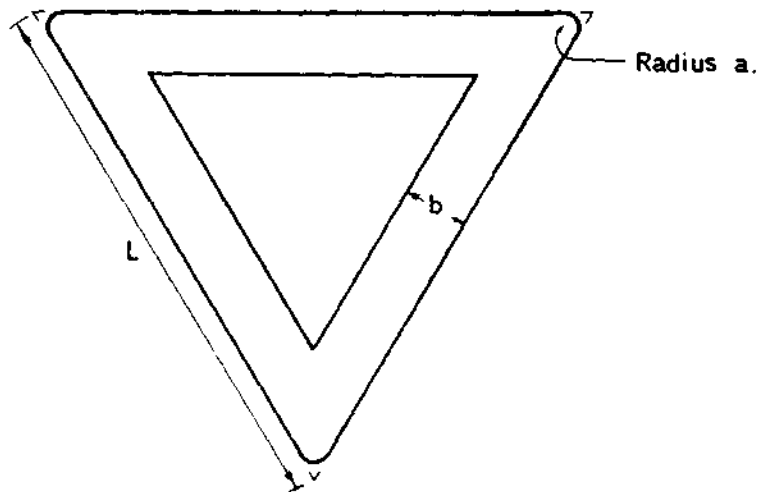

Outer triangle: Red reflectorized.
Closed triangle : Blue reflectorized

Dimensions mm.		
L	b	a
914	114	25

R3

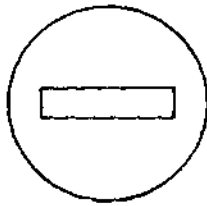

NO ENTRY.

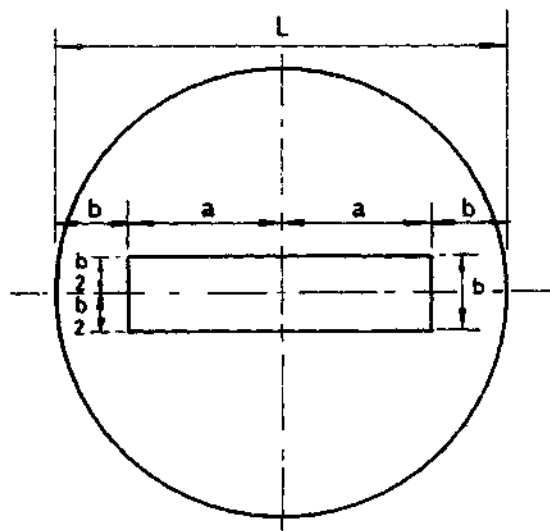

Disc: Red reflectorized
Symbol: White reflectorized.

Dimensions mm.		
L	a	b
610	203	102

R4



NO ANIMAL DRAWN VEHICLE

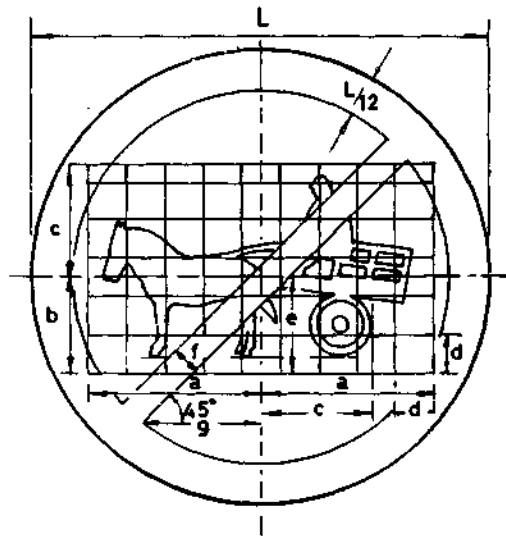

Circle and diagonal: Red reflectorized.
 Symbol: White reflectorized
 Background: Blue reflectorized.

Dimensions mm.							
L	a	b	c	d	e	f	g
610	229	127	152	51	110	38	159

R5



NO CYCLIST.

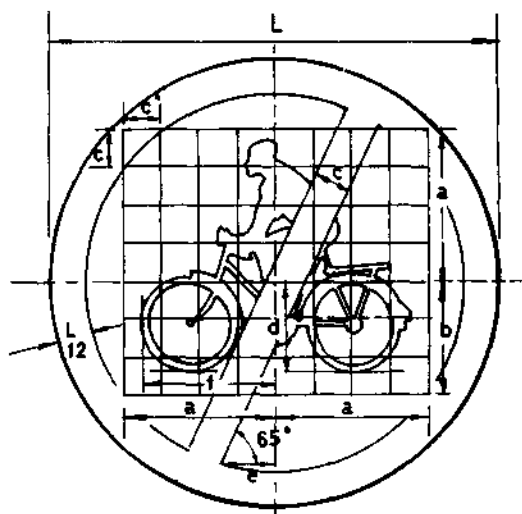

Circle and diagonal: Red reflectorized.
Symbol: White reflectorized.
Background: Blue reflectorized.

Dimensions mm.						
L	a	b	c	d	e	f
610	203	152	51	121	70	178

R6A

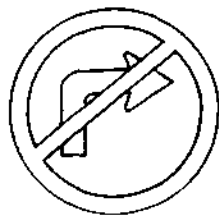

NO RIGHT TURN

R6B

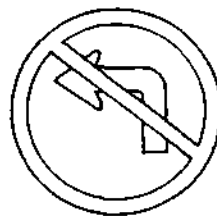

NO LEFT TURN.

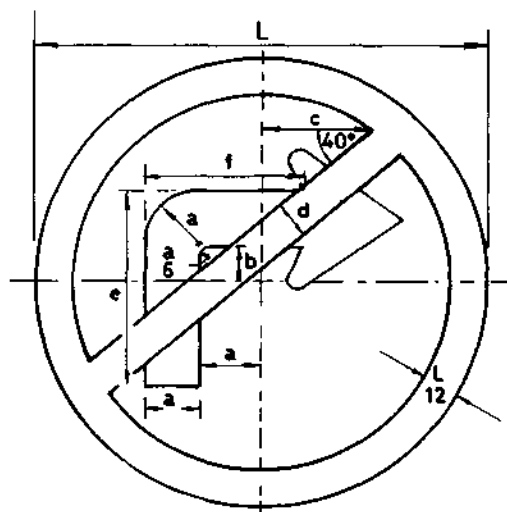

Circle and diagonal: Red reflectorized.

Symbol: White reflectorized.

Background: Blue reflectorized.

Dimensions mm.						
L	a	b	c	d	e	f
610	76	48	146	51	267	210

R7

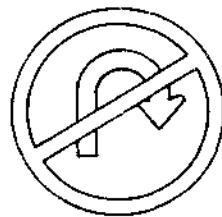

NO U TURN.

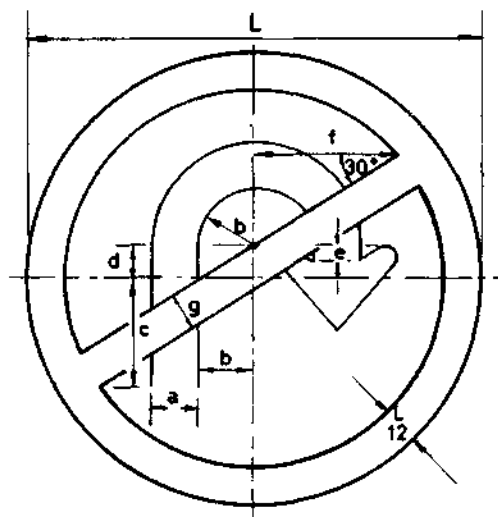

Circle and diagonal: Red reflectorized

Symbol: White reflectorized.

Background: Blue reflectorized.

Dimensions mm							
L	a	b	c	d	e	f	g
610	63	76	146	44	16	190	51

R8



NO OVERTAKING.

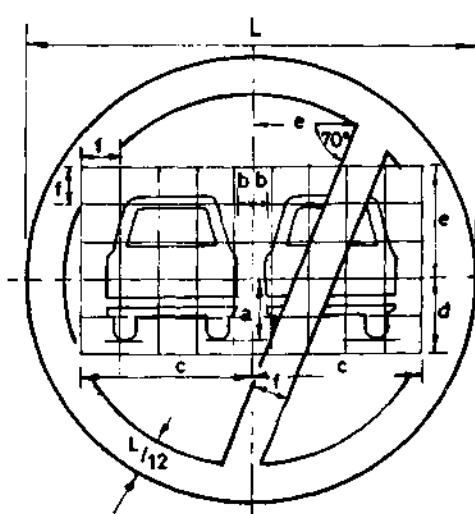

Circle and diagonal: Red reflectorized.
Symbol: White reflectorized.
Background: Blue reflectorized.

Dimensions mm.						
L	a	b	c	d	e	f
610	84	19	229	102	152	51

R9



NO PARKING

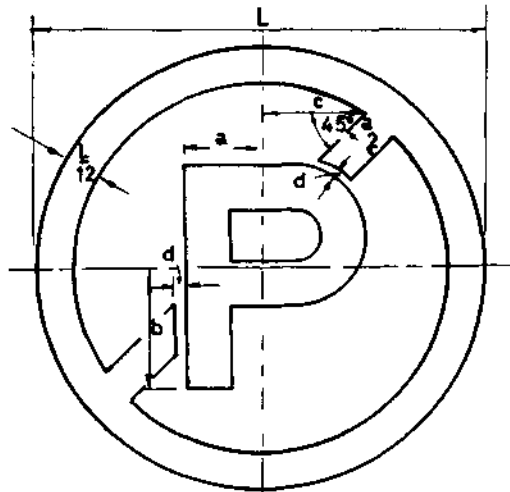

Circle and diagonal: Red reflectorized.
Letter: White reflectorized: Modified series
E alphabet .
Background: Blue reflectorized.

Dimensions mm.					
L	a	b	c	d	Letter height
610	102	165	140	10	305

R10



NO STOPPING.

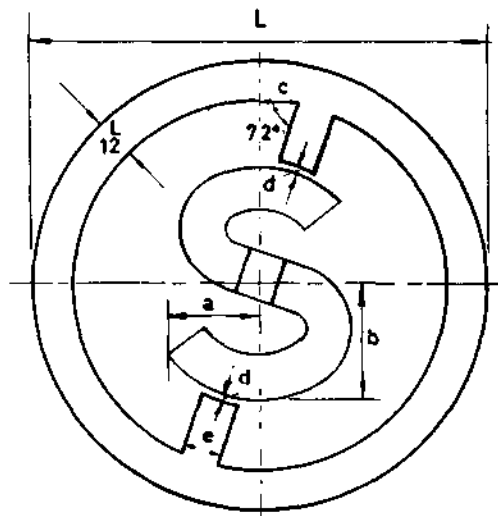

Circle and diagonal: Red reflectorized
Letter: White reflectorized: Modified series
E alphabet.
Background: Blue reflectorized.

Dimensions mm.						
L	a	b	c	d	e	Letter height
610	121	159	54	10	51	305

R 11

R 12



LIMITED HOURS NO PARKING

LIMITED HOURS NO STOPPING

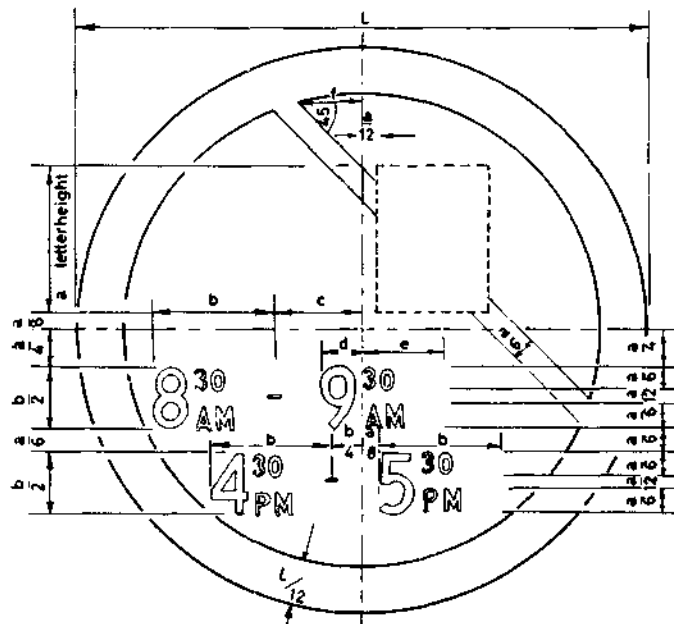
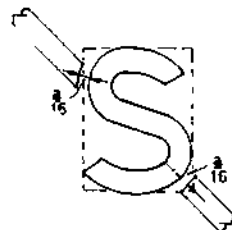
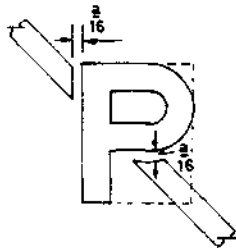

Letters P and S: Modified series E alphabet
 Legend: Series C
 Circle and diagonal: red non-reflectORIZED
 Letter and Legend: white non-reflectORIZED
 Background: blue non-reflectORIZED

Dimensions mm.						
L	a	b	c	d	e	f
610	152	127	95	44	83	73

R13A



R13B



THREE PERIODS NO
PARKING OR STOPPING.

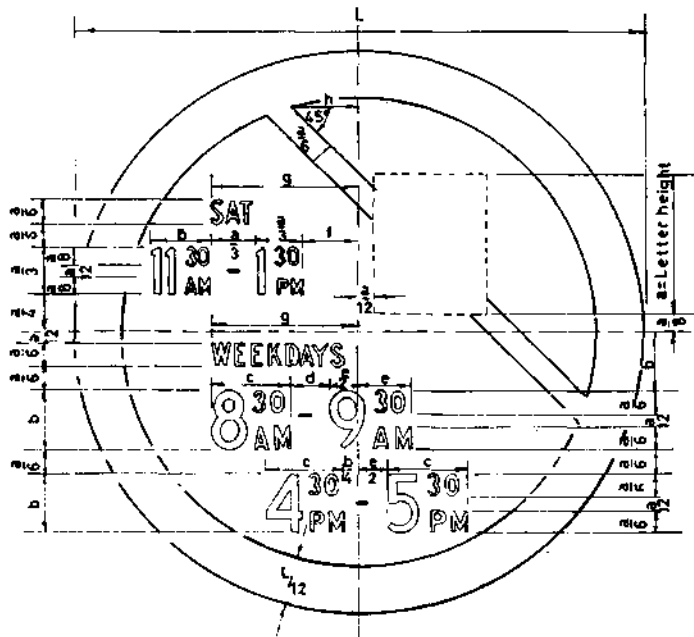
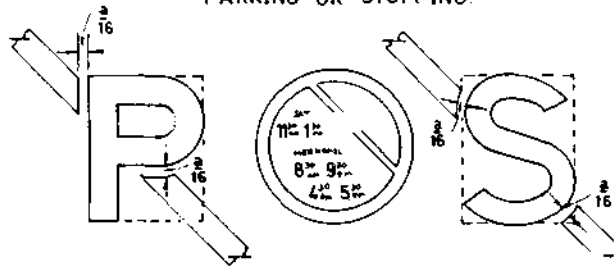

Letters P and S: Modified Series E alphabet
 Legend: Series C alphabet.
 Circle and diagonal: Red non-reflectORIZED.
 Letter and Legend: White non-reflectORIZED
 Background: Blue non-reflectORIZED

Dimensions mm								
L	a	b	c	d	e	f	g	h
610	152	63	83	44	57	60	159	73

R14



SPEED LIMIT

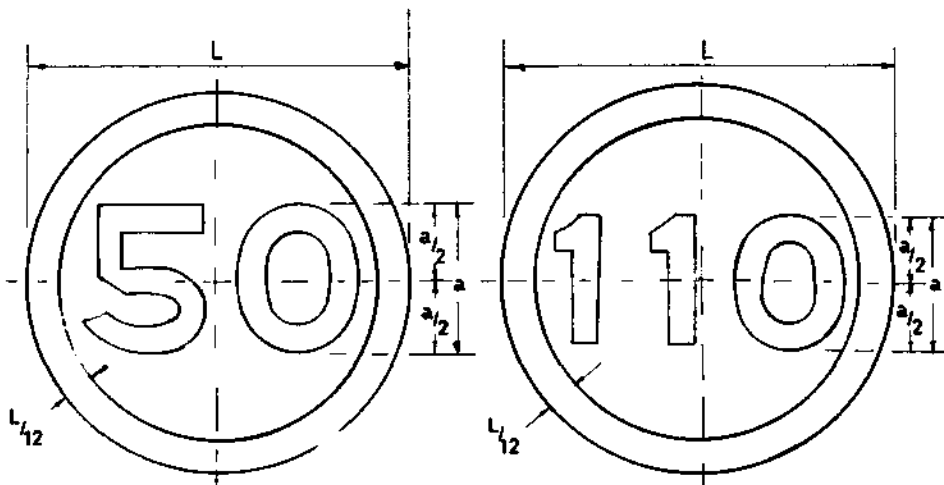

Circle: Red reflectorized
Figures: White reflectorized.
Background: Blue reflectorized.
Figures: Modified series E alphabet.

Dimensions mm.	
L	a
610	229

Dimensions mm.	
L	a
914	305

R14A



PERMISSIBLE MAXIMUM WEIGHT

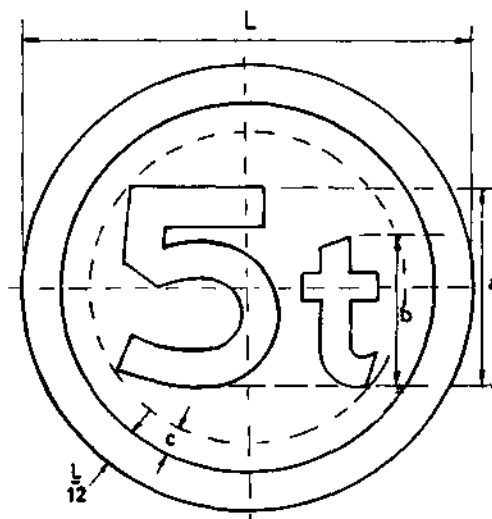

Circle: Red reflectorized
Legend: White reflectorized.
Background: Blue reflectorized
Letter and figure: Modified series
E Alphabet and figures.

Dimensions mm.			
L	a	b	c
610	271	203	46

R14B



AXLE WEIGHT LIMIT

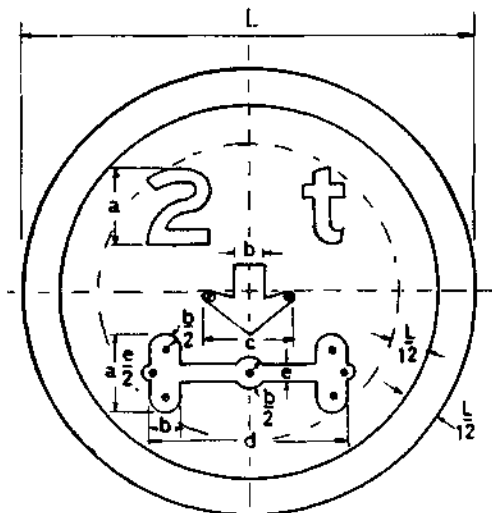

Circle: Red reflectorized
 Legend and symbol: White reflectorized.
 Background: Blue reflectorized
 Letter and figure: Modified series E
 Alphabet and figures

Dimensions mm.					
L	a	b	c	d	e
610	102	40	120	270	30

R15



ROAD CLOSED

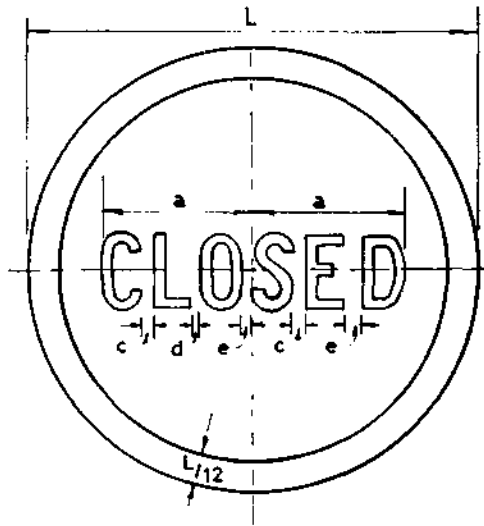

Circle: Red reflectorized
Legend: White reflectorized
Background: Blue reflectorized
Letters: Series C alphabet

Dimensions mm.						
L	a	b	c	d	e	f
914	303	311	27	17	22	152

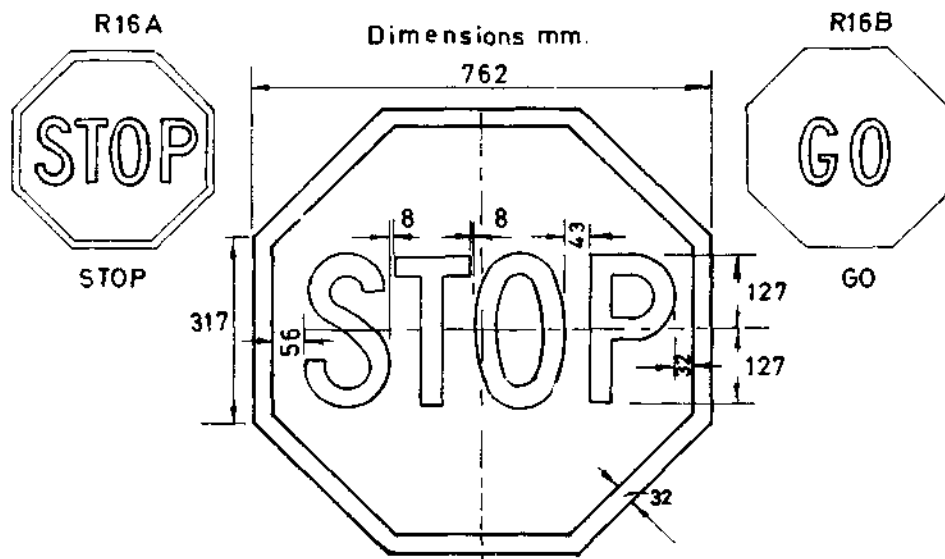

Border and Legend: White reflectorized
 Background: Red reflectorized
 Letters: Series C alphabet.

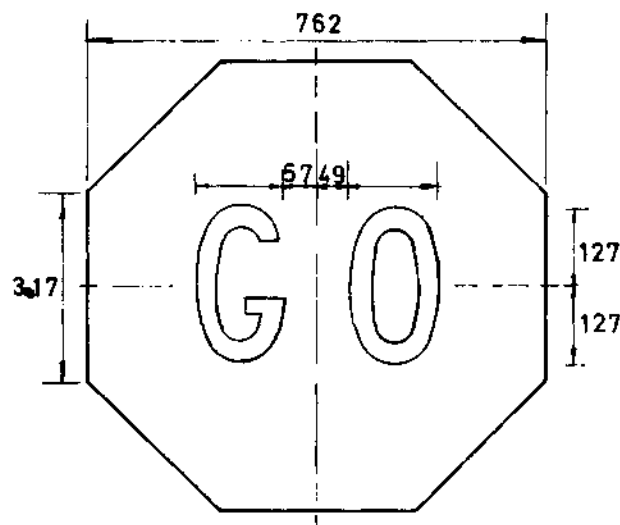

Legend: White reflectorized
 Background: Green reflectorized.
 Letters: Series C alphabet.

R17

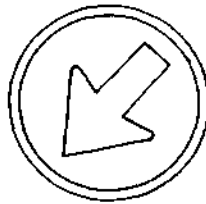

KEEP LEFT

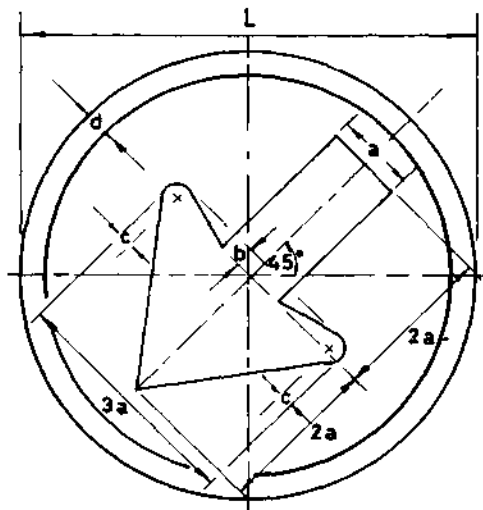

Border and arrow: White reflectorized
Background: Blue reflectorized

Dimensions mm.				
L	a	b	c	d
610	108	25	19	32

R18A

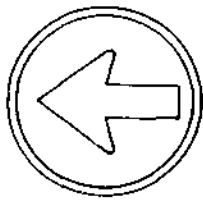

R18B

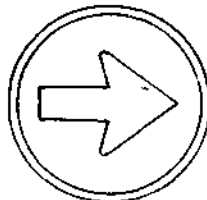

R18C

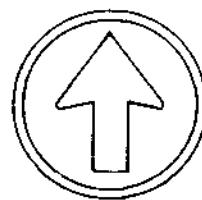

PROCEED LEFT ONLY.

PROCEED STRAIGHT ON ONLY.

PROCEED RIGHT ONLY.

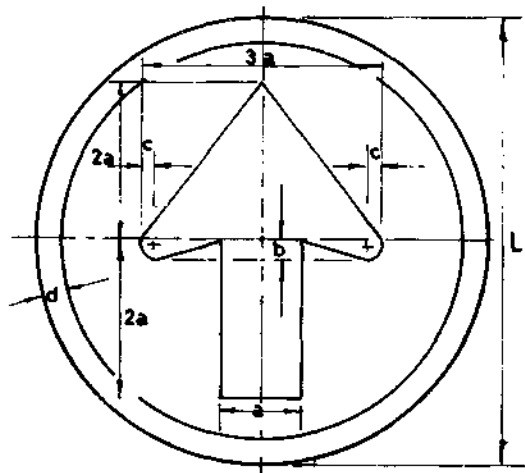

Border and arrow: White reflectorized

Background: Blue reflectorized.

Dimensions mm				
L	a	b	c	d
610	108	25	19	32

R19A

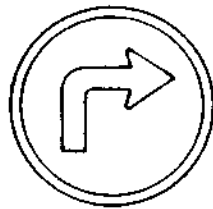

TURN RIGHT

R19B

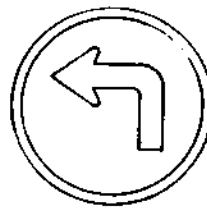

TURN LEFT

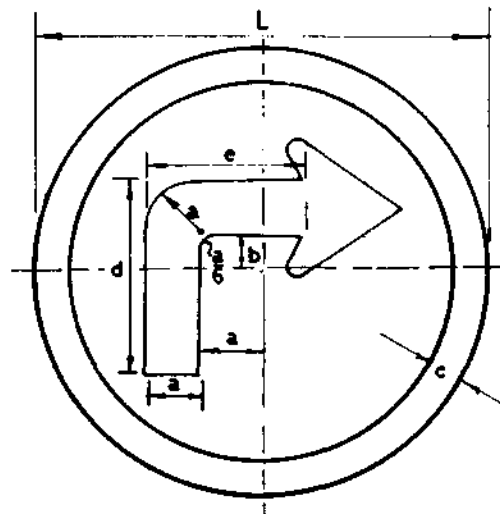

Border and arrow: White reflectorized.
Background: Blue reflectorized

Dimensions mm					
L	a	b	c	d	e
610	76	48	32	267	210

R20

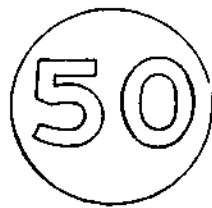

MINIMUM SPEED

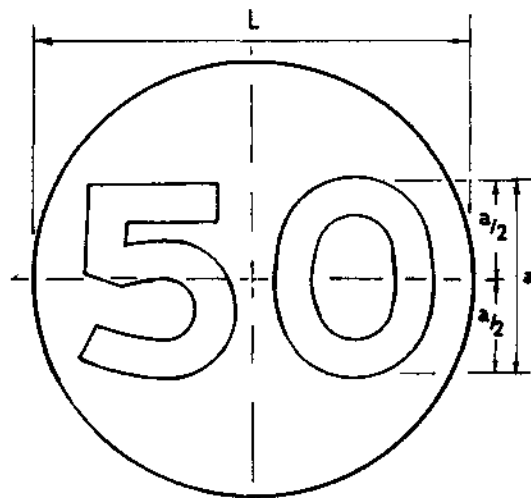

Figures: White reflectorized.
Disc: Blue reflectorized
Figures: Modified series E alphabet.

Dimensions mm	
L	a
610	271

R21



CYCLISTS ONLY.

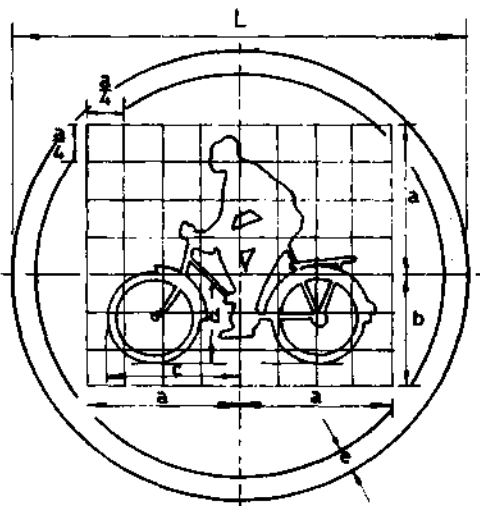

Border and symbol: White reflectorized
Background: Blue reflectorized.

Dimensions mm					
L	a	b	c	d	e
610	203	152	178	121	32

R22



LIMITED PARKING

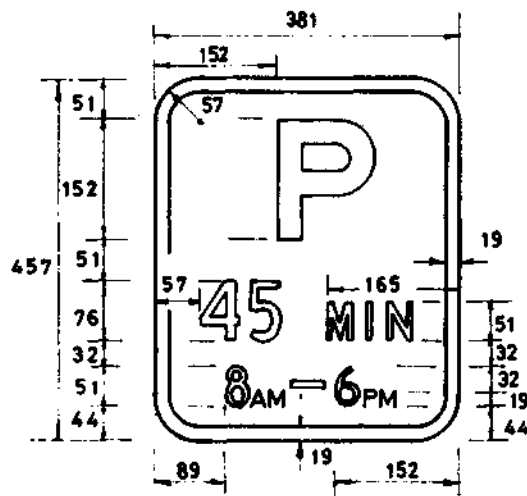

Dimensions mm.

Border, letter and legend: White non-reflectORIZED
Background: Blue non-reflectORIZED
Letter P: Modified series E alphabet.
Period: series C.

WARNING SIGNS

Unless otherwise specified:-

Border: red reflectorized

Background: blue reflectorized

Symbol: white reflectorized

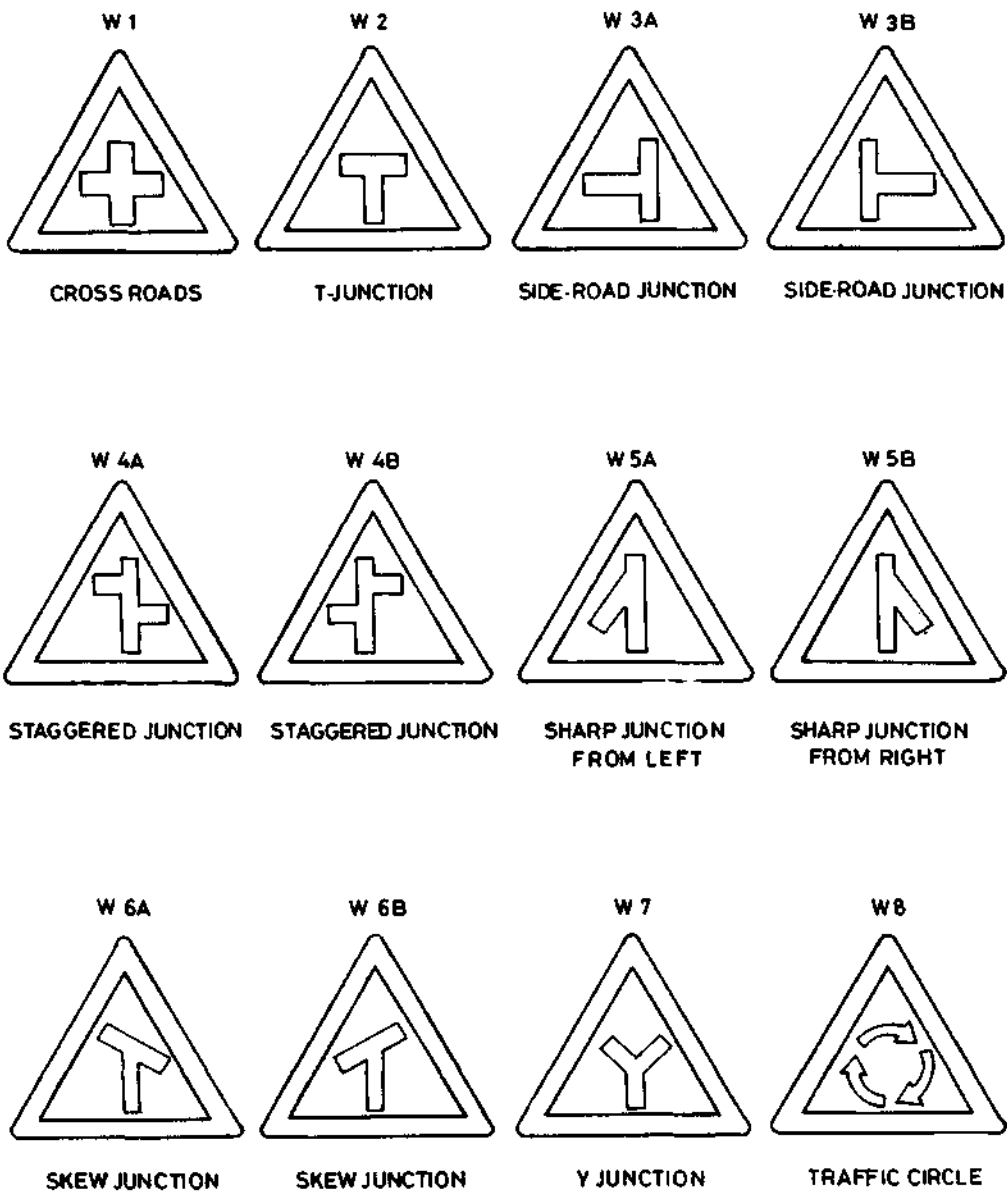

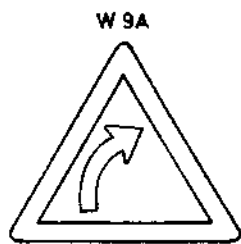

W 9A
GENTLE CURVE TO RIGHT

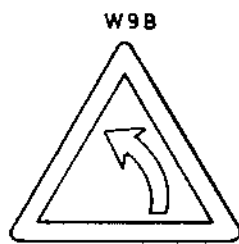

W 9B
GENTLE CURVE TO LEFT



W 10A
SHARP CURVE TO RIGHT

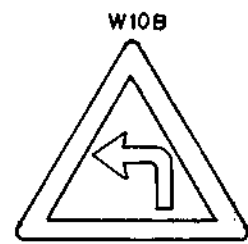

W 10B
SHARP CURVE TO LEFT



W 11A
HAIRPIN BEND TO RIGHT



W 11B
HAIRPIN BEND TO LEFT



W 12A
REVERSE CURVES



W 12B
REVERSE CURVES

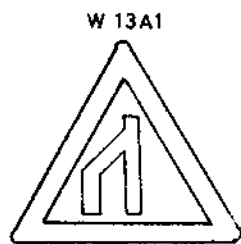

W 13A1
END OF DUAL ROADWAYS

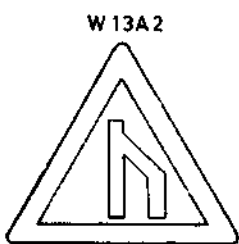

W 13A2
END OF DUAL ROADWAYS



W 13B1
BEGINNING OF DUAL ROADWAYS

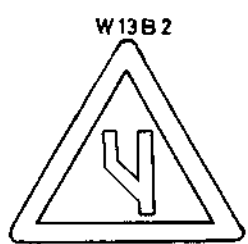

W 13B2
BEGINNING OF DUAL ROADWAYS

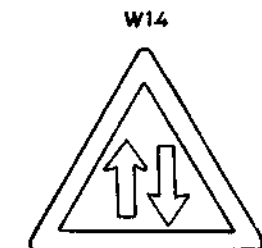

W 14
TWO WAY TRAFFIC

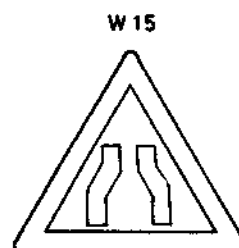

W 15
ROAD NARROWS FROM BOTH SIDES

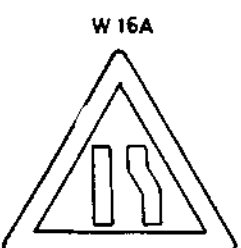

W 16A
ROAD NARROWS FROM ONE SIDE ONLY

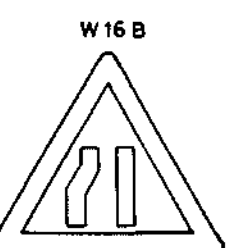

W 16B
ROAD NARROWS FROM ONE SIDE ONLY

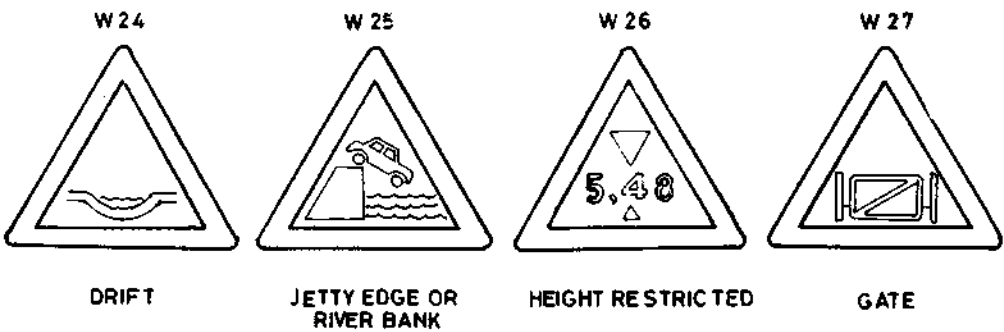
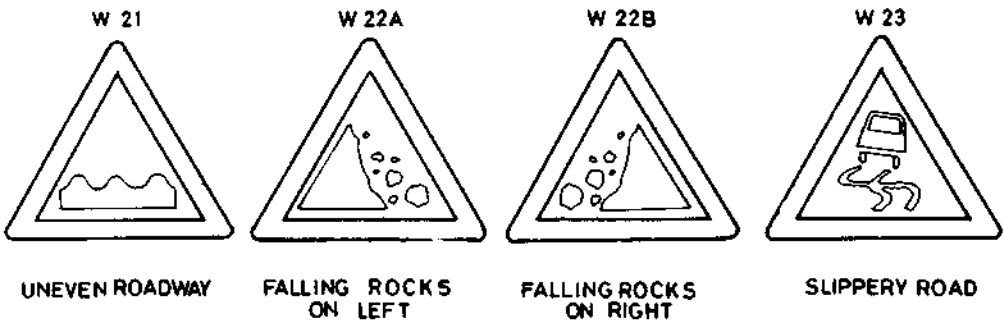
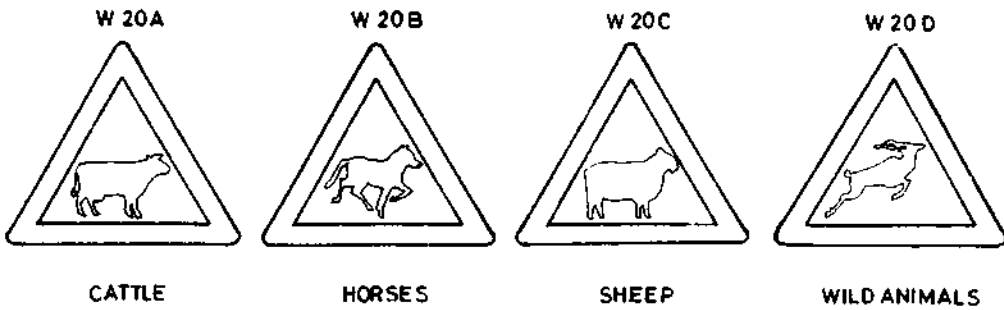
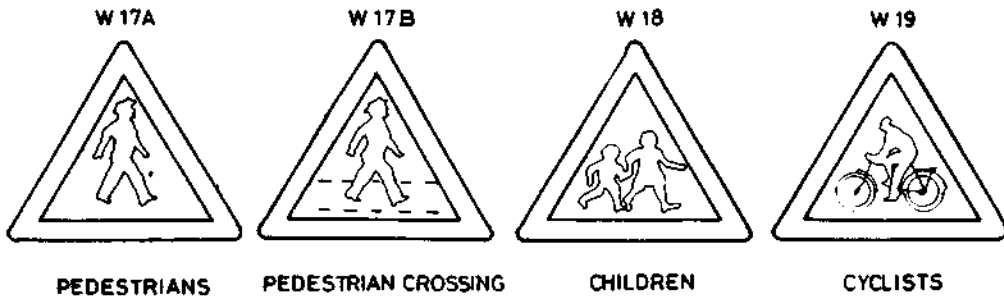

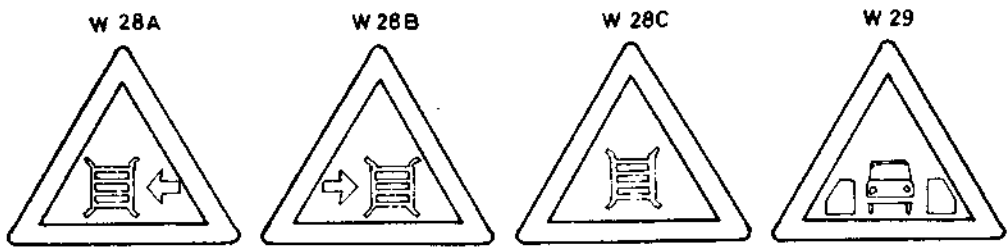

W 28A
CATTLE GRID
ON LEFT



W 28B
CATTLE GRID
ON RIGHT

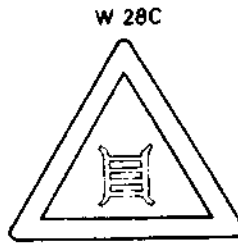

W 28C
CATTLE GRID
MIDDLE OF ROADWAY

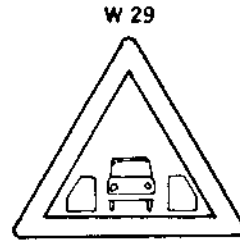

W 29
ONE VEHICLE WIDTH
STRUCTURE

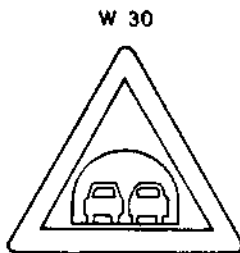

W 30
TUNNEL

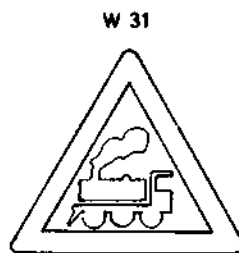

W 31
UNGUARDED LEVEL
CROSSING

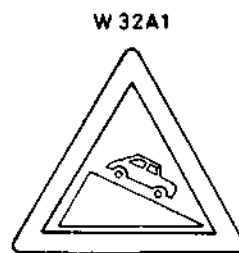

W 32A1
STEEP DESCENT
TO RIGHT.

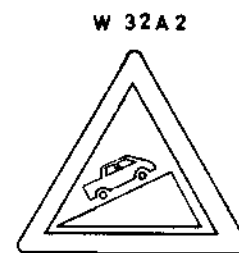

W 32A2
STEEP DESCENT
TO LEFT.



W 32B1
STEEP ASCENT
TO LEFT

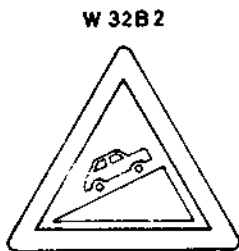

W 32B2
STEEP ASCENT
TO RIGHT



W 33
CROSS-WINDS

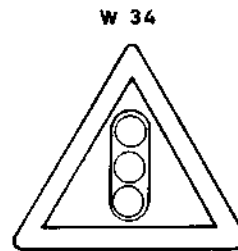

W 34
TRAFFIC SIGNALS
AHEAD

Signals (in descending order
Red, amber, green reflector)

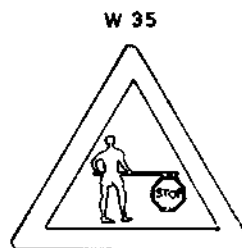

W 35
SCHOLAR PATROL
AHEAD

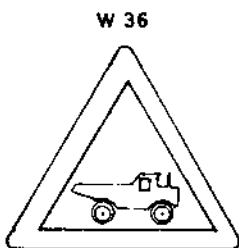

W 36
TRUCKS CROSSING

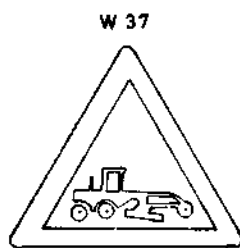

W 37
GRADER WORKING

Stop symbol: Red reflectorized.

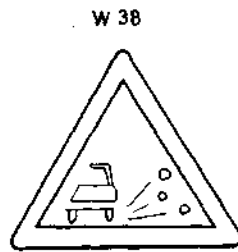

LOOSE STONES

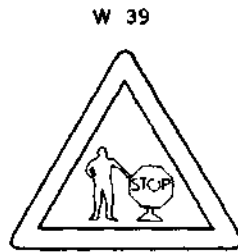

STOP/GO CONTROL
AHEAD
(Stop Symbol: red
reflectorized)



ROAD WORKMEN

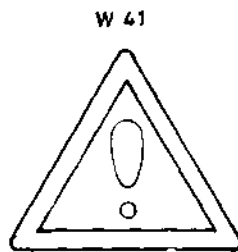

HAZARD WARNING

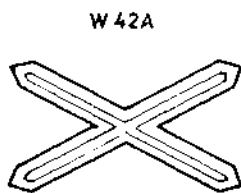

LEVEL CROSSING WARNING-
CROSS - ONE TRACK

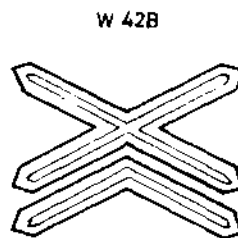

LEVEL CROSSING WARNING-
CROSS - TWO TRACKS

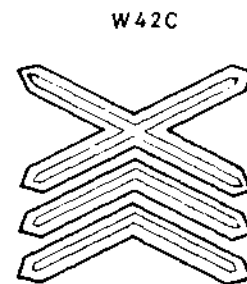

LEVEL CROSSING WARNING-
CROSS - THREE TRACKS

Border: red reflectorized
Background: white non-reflectorized

GUIDE OR INFORMATIVE SIGNS

Unless otherwise specified :-

Border : white reflectorized.

Background : green reflectorized

Symbol : white reflectorized

G 1A

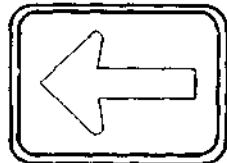

ONE-WAY ROADWAY -
LEFT

G 1B

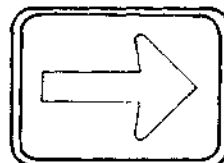

ONE-WAY ROADWAY -
RIGHT

G 2

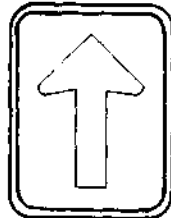

ONE-WAY ROADWAY
STRAIGHT ON

G 3

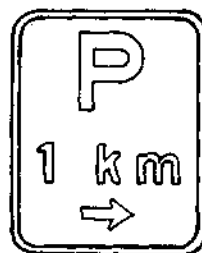

PARKING AREA
AHEAD

G 5



STOPPING PLACE
AHEAD

G 4

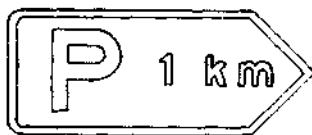

PARKING AREA DIRECTION

G 6

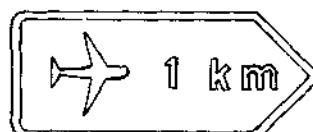

MINOR AIRFIELD DIRECTION

G 7

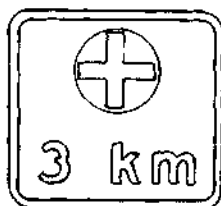

HOSPITAL OR
FIRST-AID POST

G 8

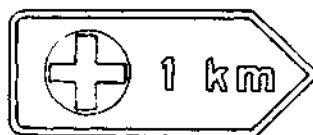

HOSPITAL OR FIRST-AID
POST DIRECTION

G 9



HOTEL OR MOTEL

Cross : red reflectorized.



MOTEL OR HOTEL
DIRECTION

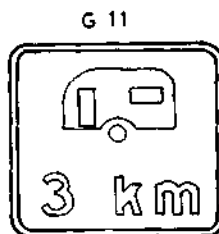

CARAVAN SITE

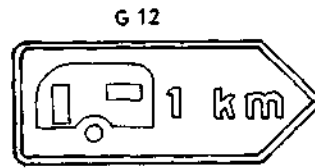

CARAVAN SITE
DIRECTION

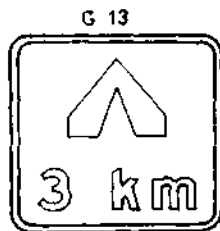

CAMPING SITE

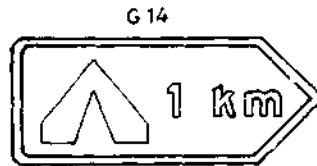

CAMPING SITE DIRECTION

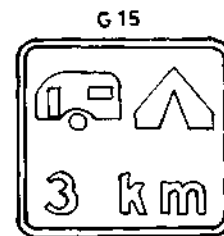

CARAVAN AND
CAMPING SITE

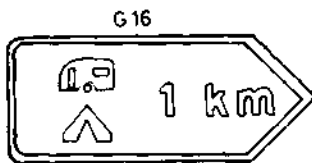

CARAVAN AND CAMPING
SITE DIRECTION

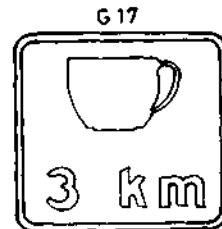

RESTAURANT

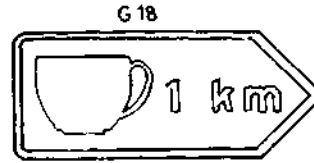

RESTAURANT DIRECTION

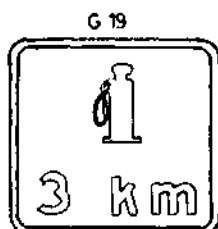

FILLING STATION

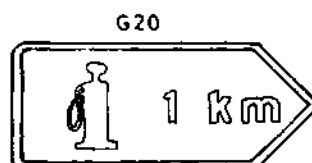

FILLING STATION DIRECTION

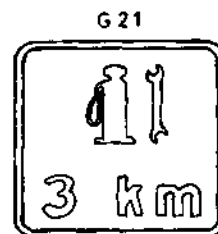

FILLING AND SERVICE
STATION

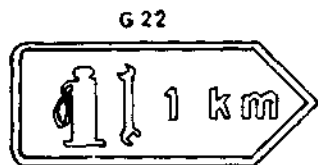

FILLING AND SERVICE
STATION DIRECTION



TELEPHONE DIRECTION

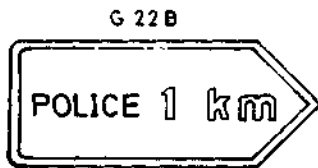

POLICE STATION
DIRECTION



WATER AHEAD

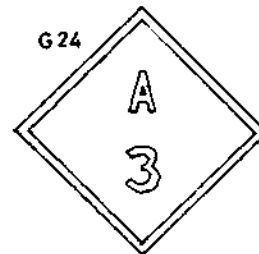

MAJOR ROAD
ROUTE MARKER

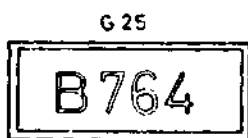

MINOR ROAD
ROUTE MARKER



STOP AHEAD

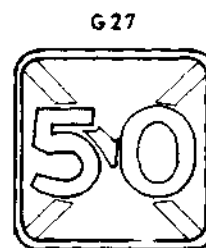

DE-RESTRICTION
Background: blue reflectorized
Diagonals: red reflectorized.

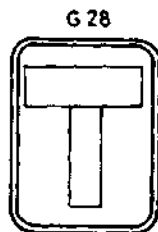

CUL-DE-SAC
Cross bar of T:
red reflectorized.

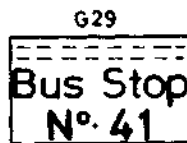

BUS STOP
Background: white non-reflectorized.
Legend: black.

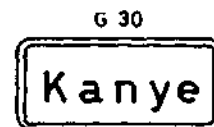

TOWN NAME

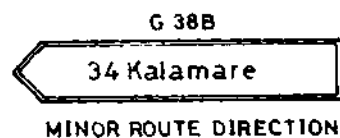
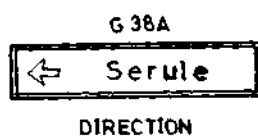
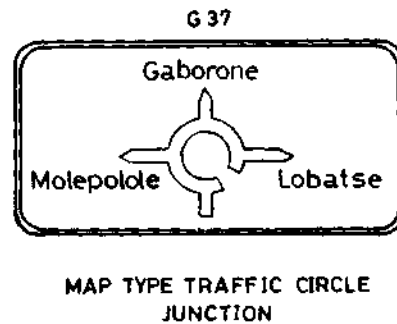
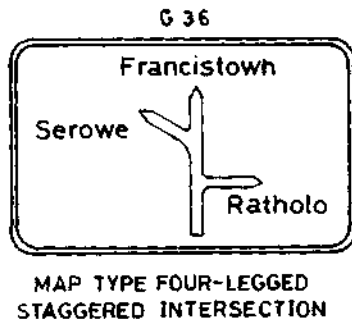
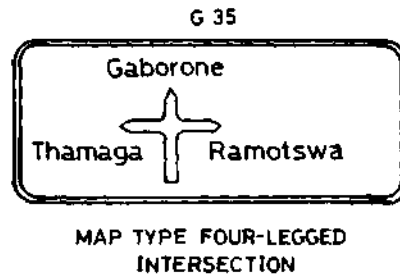
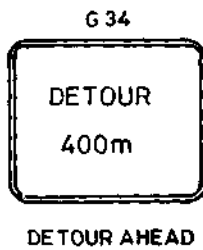
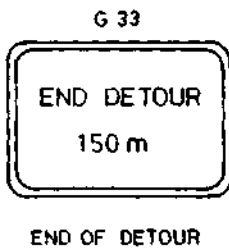
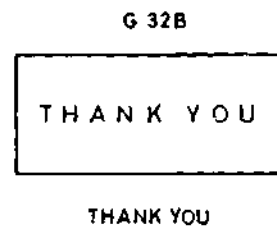
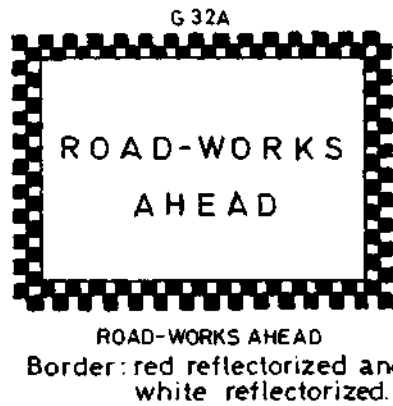

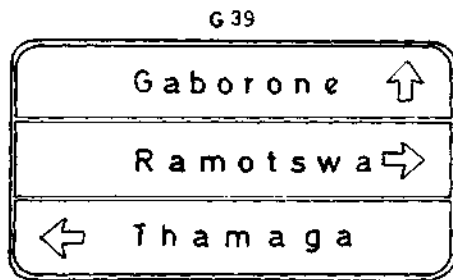

STACK TYPE DIRECTION

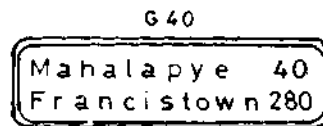

CONFIRMATION

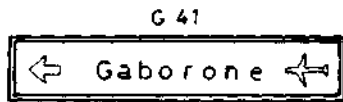

AIRPORT DIRECTION

G 42A



G 42B



DANGER PLATES
Alternate bands
red reflectorized and
white reflectorized.



JUNCTION CHEVRON

Alternate chevrons yellow,
reflectorized and black.

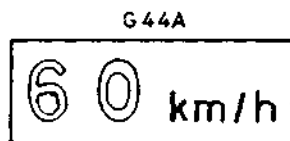

RECOMMENDED SPEED
INFORMATION PLATE

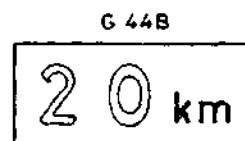

DISTANCE INFORMATION
PLATE

CLASS B-ROAD MARKINGS.
REGULATORY MARKS.

Unless otherwise stated, all road markings white.

RM 1

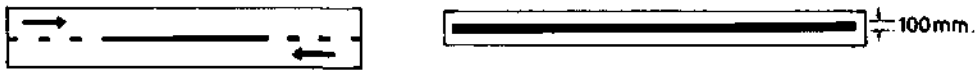

BARRIER LINE

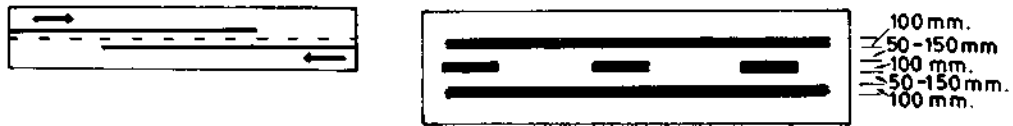

BARRIER LINES WITH CENTRE-LINE.

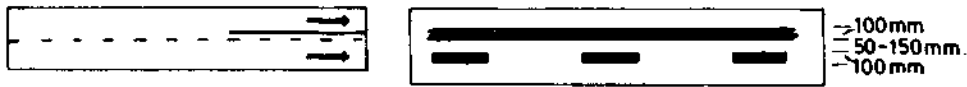

BARRIER LINE WITH LANE-LINE

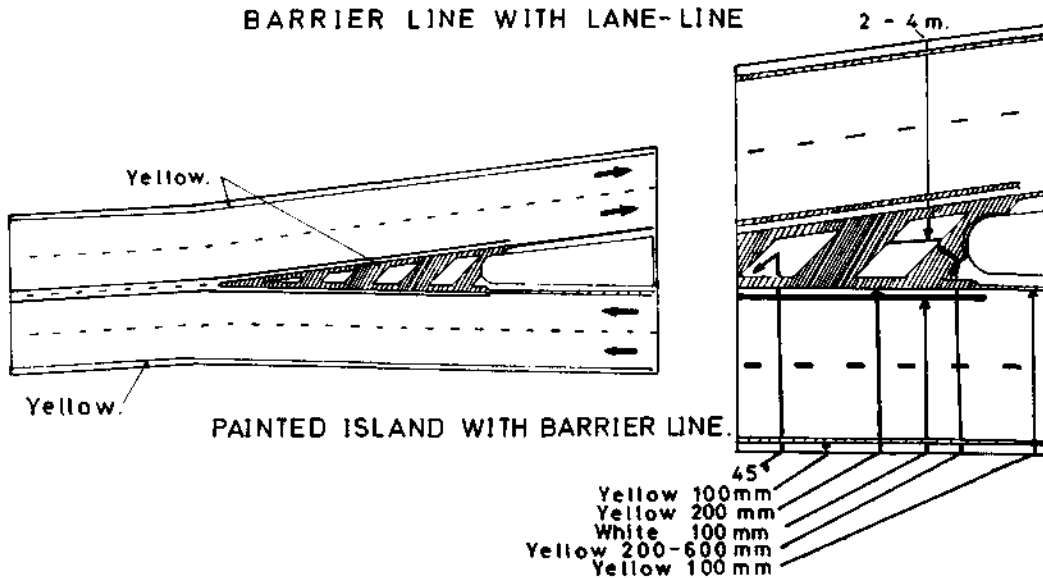

PAINTED ISLAND WITH BARRIER LINE.

RM 2

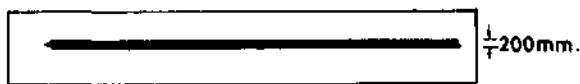

WHITE CHANNELISING LINE

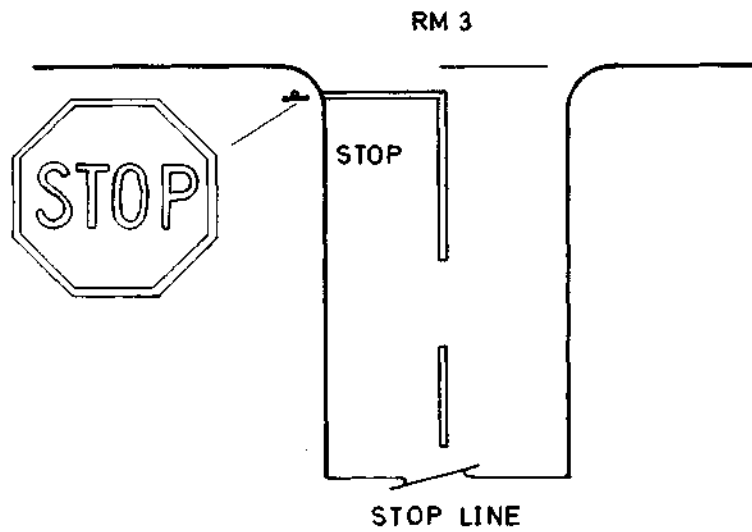

Dimensions: Width of stop line
 Urban area 300mm.
 Other areas 500mm.

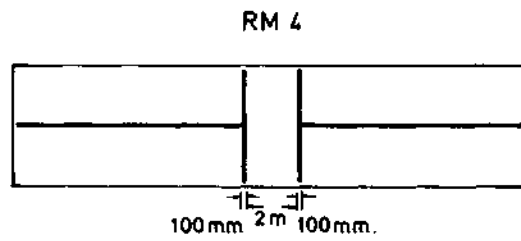

PEDESTRIAN CROSSING LINES.

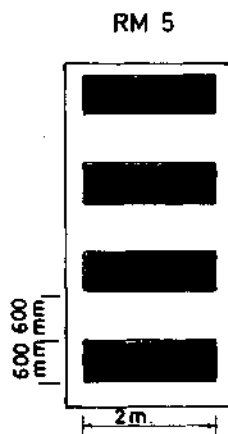

BLOCK PEDESTRIAN CROSSING.

RM 6

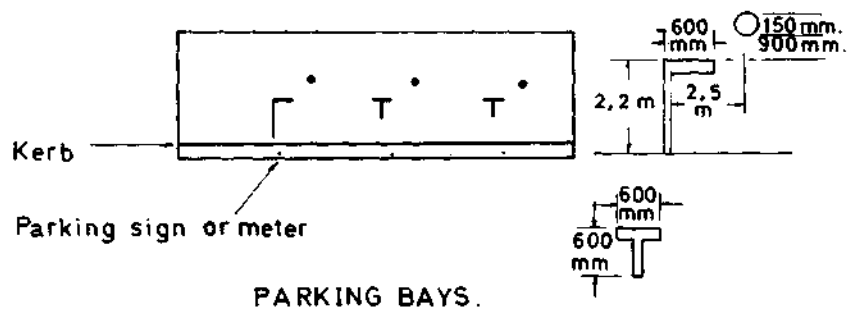

RM 7

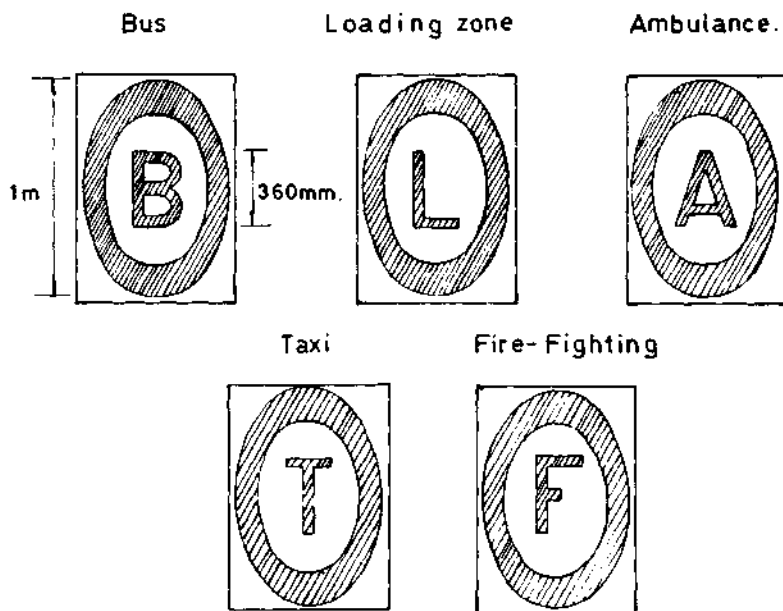

EXCLUSIVE PARKING BAYS.

Symbol & Letters Yellow.

RM 8

TURN LEFT ONLY. PROCEED STRAIGHT ON.
Straight on or right turn prohibited. Left or right turn prohibited

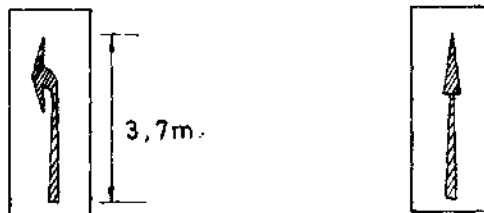

TURN RIGHT ONLY.
Straight on or left turn prohibited.



PROCEED STRAIGHT ON
OR
TURN RIGHT.
Left turn prohibited.



PROCEED STRAIGHT ON
OR
TURN LEFT.
Right turn prohibited.

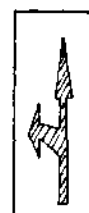

DIRECTIONAL ARROWS.
Symbol yellow.

WARNING MARKINGS

WM 1

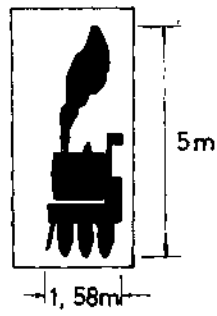

LEVEL CROSSING MARKINGS

GUIDE OR INFORMATIVE MARKINGS.

GM 1

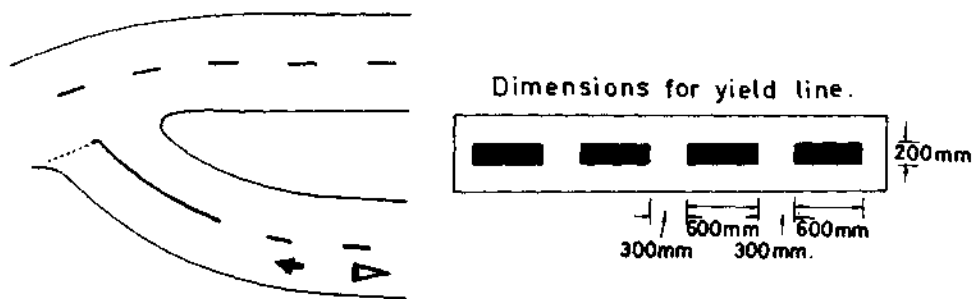

YIELD LINE.

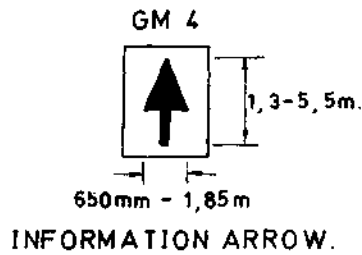
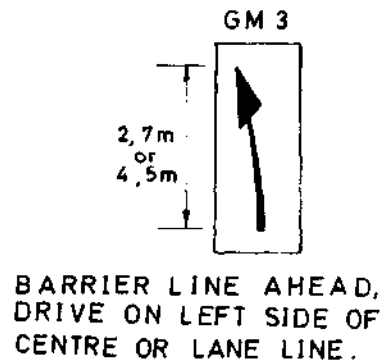
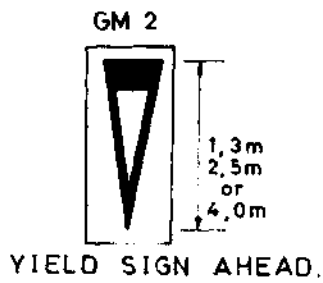

CLASS C-ROAD SIGNALS.
REGULATORY SIGNALS.

RS 1

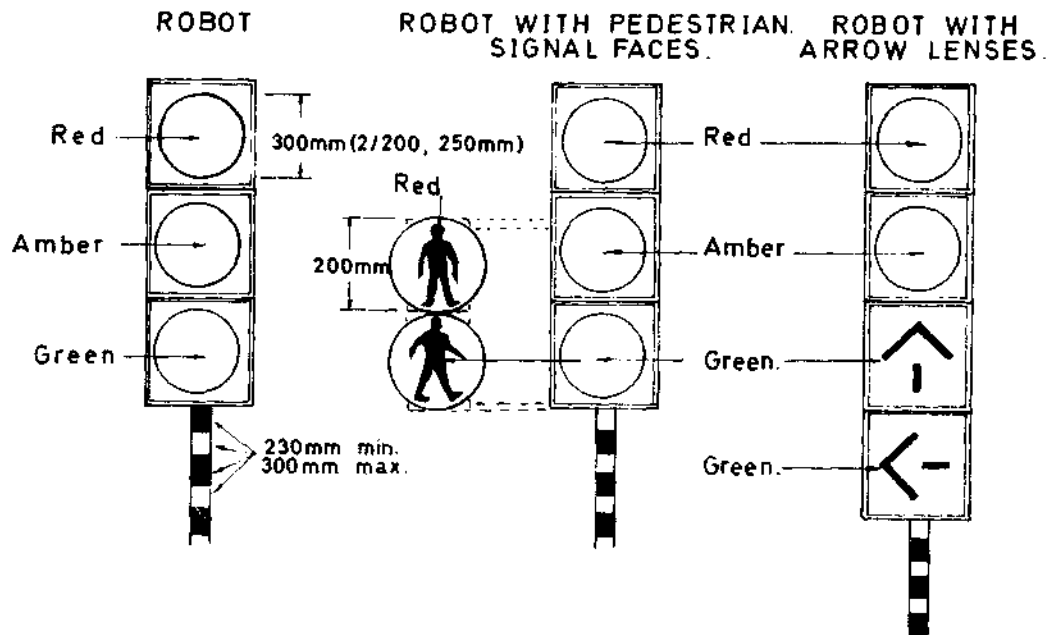

SCHEDULE 2
ROAD TRAFFIC SIGNS

MODIFIED SERIES E ALPHABET

Proportions with letter height equal to 100

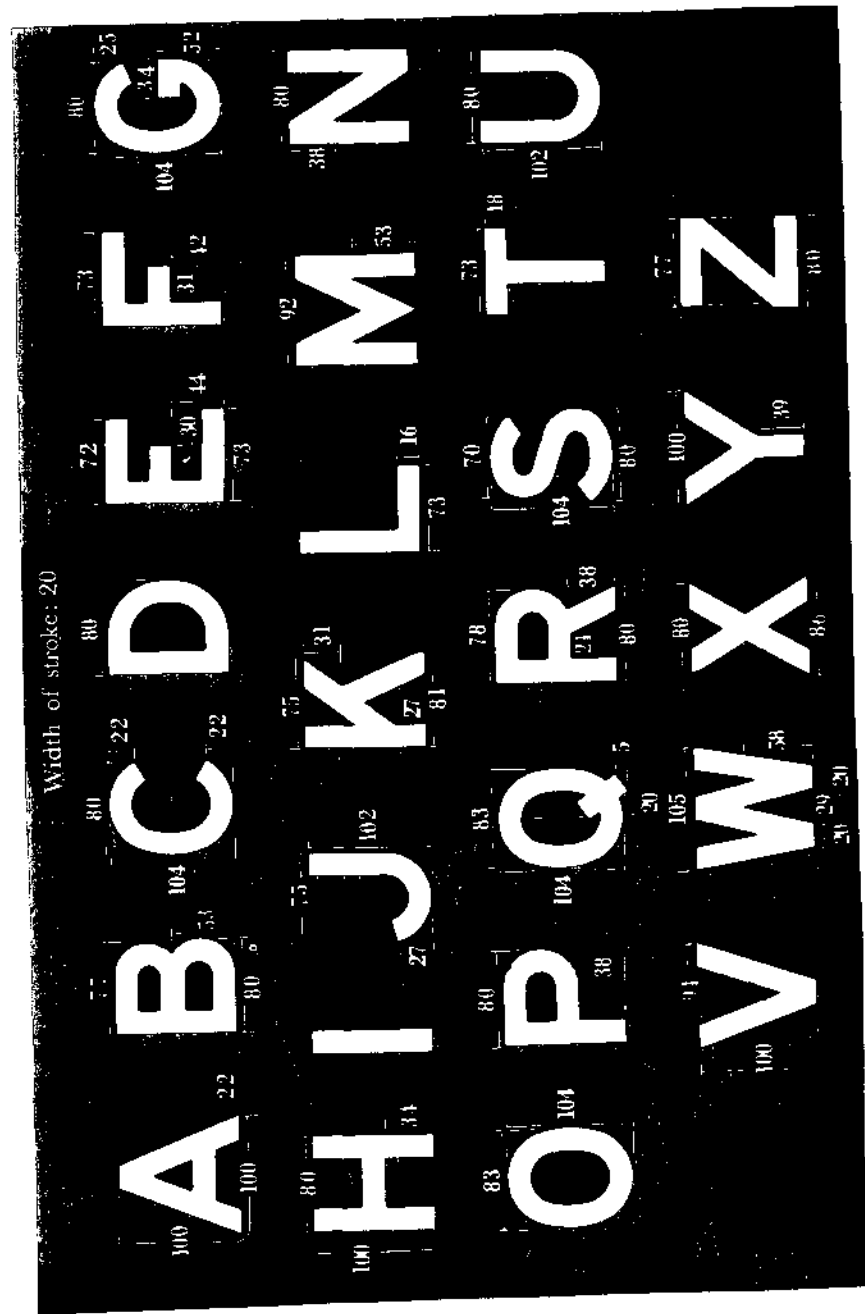

MODIFIED SERIES E LOWER CASE ALPHABET

Proportions with height of main body letters 100 and width of stroke generally 95

a b c d e f g h i j k l m n

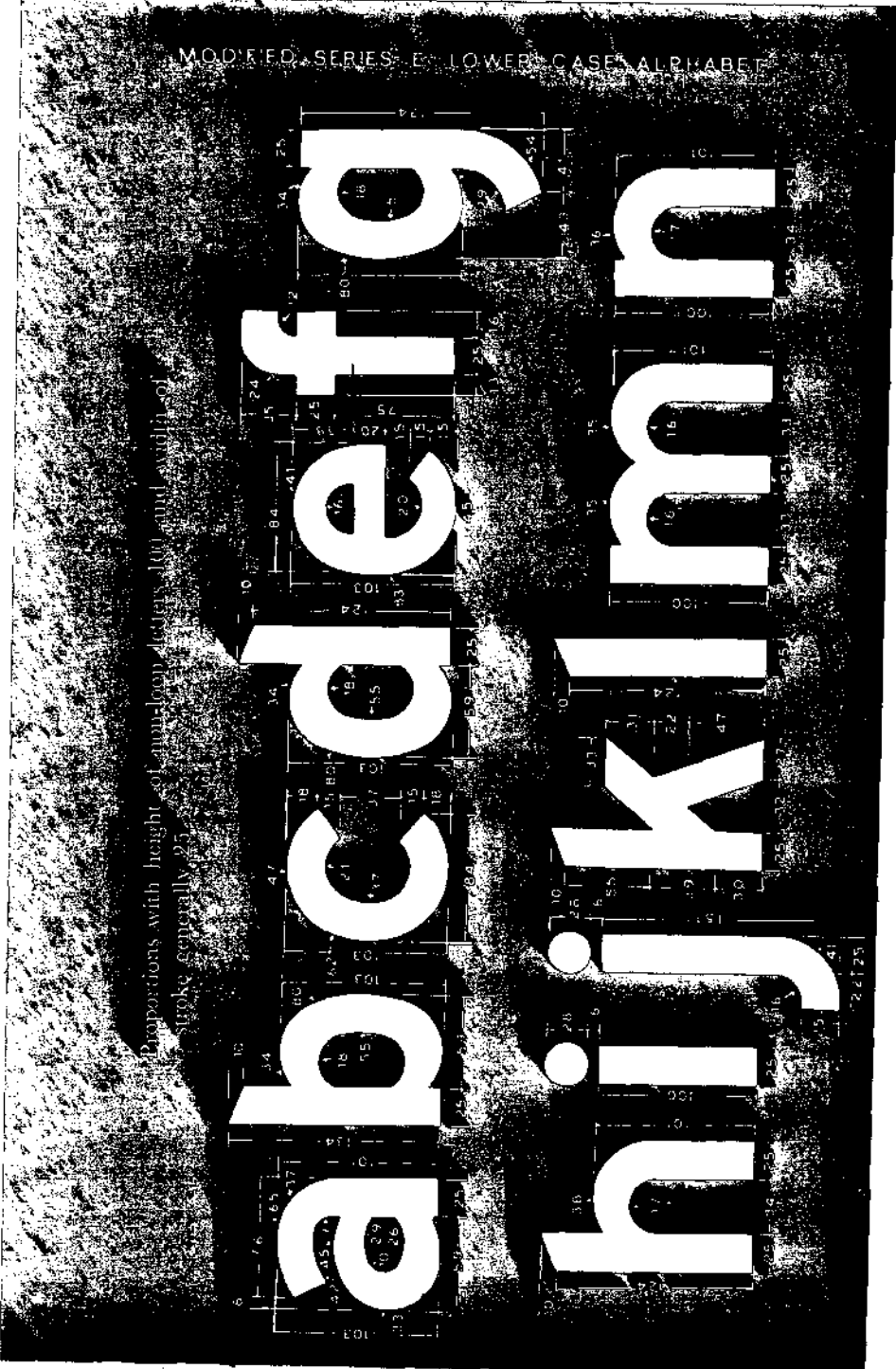

o p q r s t u

v w x y z

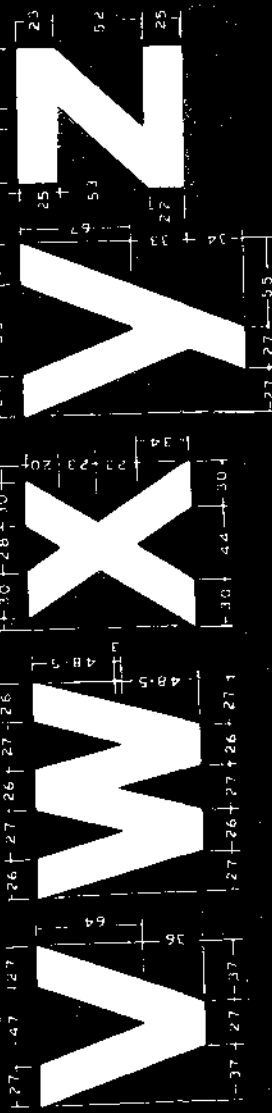
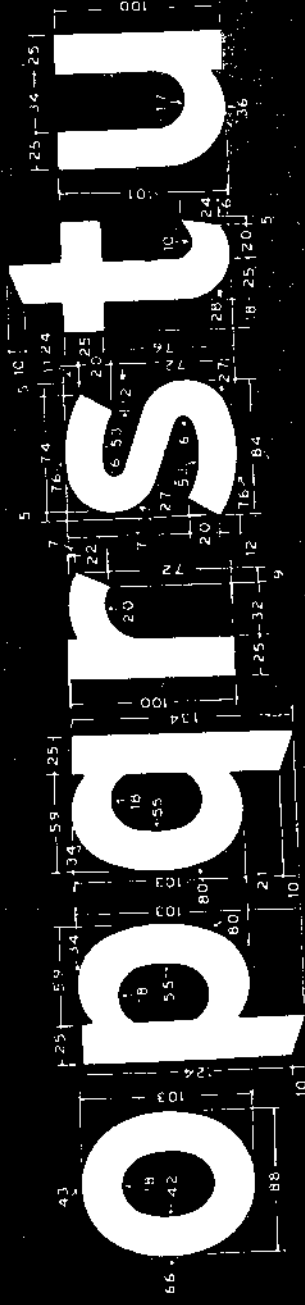

SERIES C ALPHABET

Proportions with letter height equal to 100

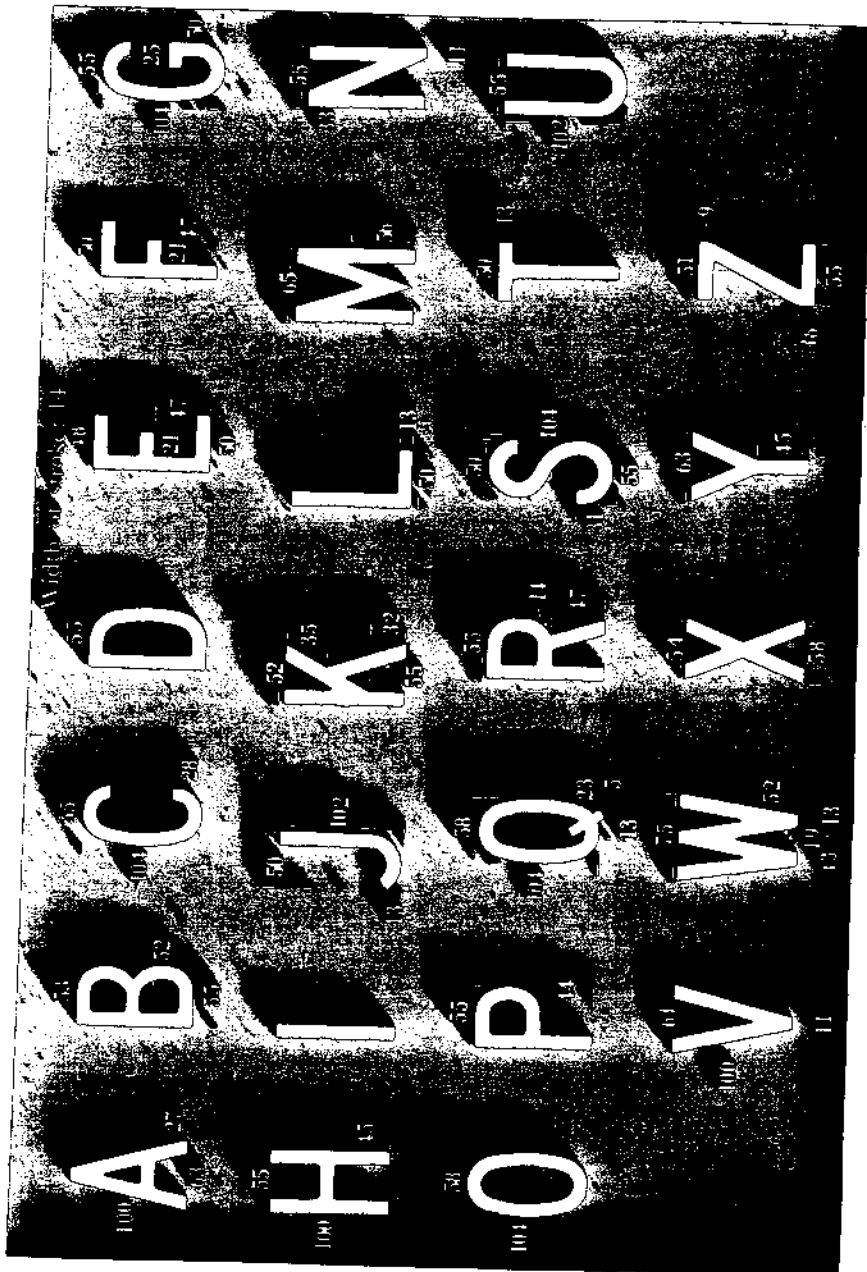

MODIFIED SERIES E FIGURES AND SERIES C FIGURES

Proportions with letter height equal to 100

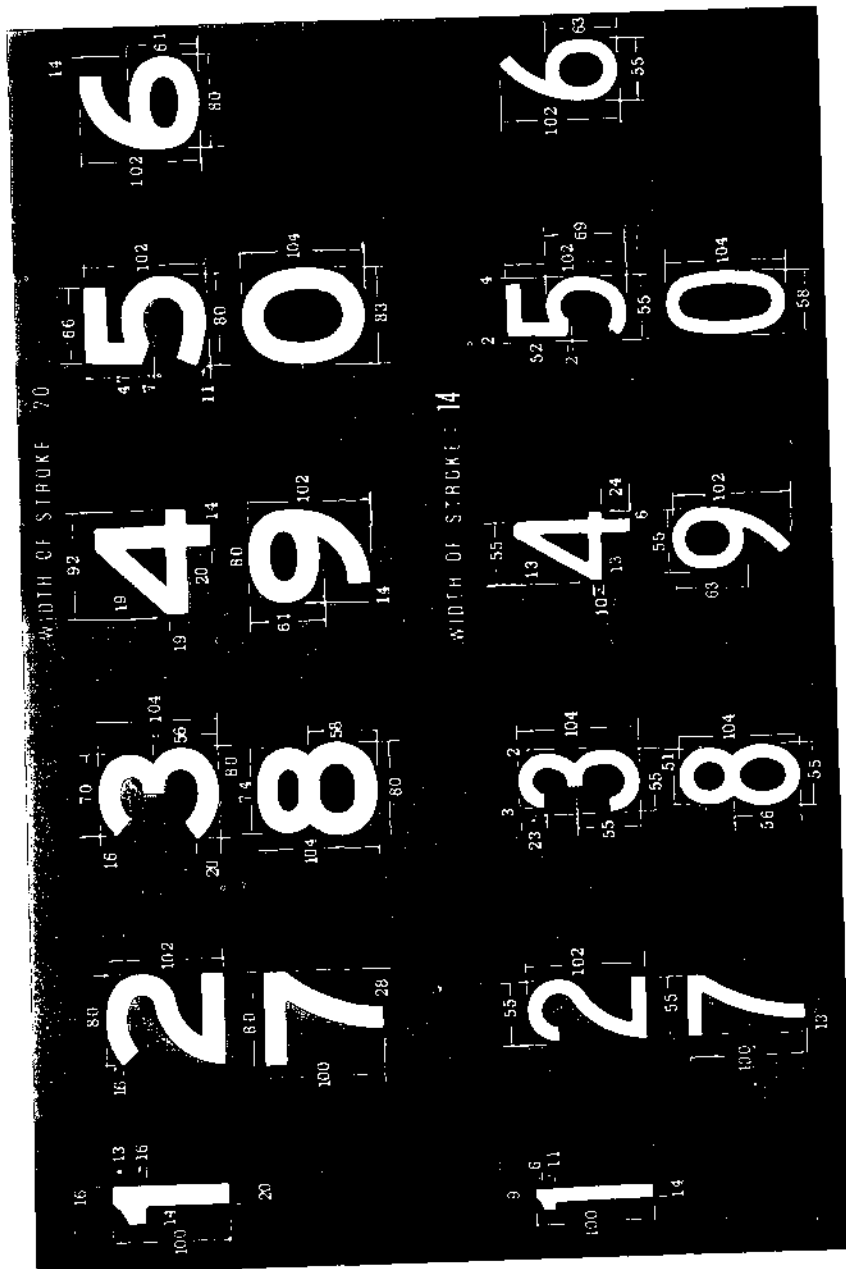

ALPHABET AND FIGURES FOR ROAD MARKINGS

Proportions with height equal to 1 000

Width of stroke : 150 mm, W 100 mm, of K 180 mm

Width of letter or figure : 510 mm, A & M 610 mm



MADE this 6th day of November, 1974.

L.D. LEKALAKE,
Permanent Secretary,
Ministry of Works and Communications

L2/7/209